

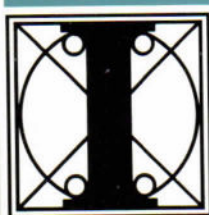

L1 MOS

Operating Guide

M54 - M64 - M70



olivetti

PUBLICATION ISSUED BY:

Ing. C. Olivetti & C., S.p.A.
Direzione Documentazione
77 Via Jervis 10015 IVREA (Italy)

*Copyright © 1987, by Olivetti
All rights reserved*

Ethernet is a trademark of Xerox Corporation

Omninet is a trademark of Corvus System Inc.

IBM is a trademark of International Business Machine Co.

UNIX is a trademark of AT&T

Z8000 is a trademark of Zilog Corporation

MS-DOS is a trademark of Microsoft Inc.

VT-100/VT-200 are trademarks of Digital Research



L1 MOS

Operating Guide

M54 - M64 - M70

olivetti

PREFACE

This manual is intended to describe the main components of the L1 MOS systems (M54/M64/M70). It provides information on the correct use of the hardware and software procedures run on these systems.

SUMMARY

The manual is divided into two parts. The first part (from chapter 2 to 6) describes the main system components (i.e., basic unit, work station, etc.) and how to use the console and the system's peripheral units.

The second part (from chapter 7 to 10) describes how the system operates and how to use it. The Shell environment is illustrated here, in this part, together with details on some of its commands.

At the end of the manual there are two appendices containing the error and warning messages associated to autodiagnostic and IPL procedures.

PRE-REQUISITE: none

REFERENCES:

L1 MOS System Summary Code: 4036140 Z
Introduction to MOS Code: 4002130 G
Hardware Configuration Guide Code: 4036120 X
MOS SHELL Command Reference Manual Code: 4002770 Q
MCL MOS Command Language Code: 4002220 H
MOS Editor Reference Manual Code: 4002440 N
Message Book Code: 4002260 D
System Software Generation and Installation Code: 4002160 B

DISTRIBUTION: General

FIRST EDITION: April 1987

CONTENTS

1. INTRODUCTION

HARDWARE STRUCTURE	1-2
SOFTWARE CHARACTERISTICS	1-2

2. BASIC UNIT

M54 BASIC UNIT	2-1
THE BOARD RACK	2-2
MAGNETIC UNITS	2-3
M64 BASIC UNIT	2-4
THE BOARD RACK	2-5
MAGNETIC UNITS	2-6
M70 BASIC UNIT	2-7
THE BOARD RACK	2-9
MAGNETIC UNITS	2-10
CAB 7019	2-11
CAB 7018	2-12

3. CONSOLE

BASIC CONSOLE	3-1
EXTENDED CONSOLE	3-2

THE KEYBOARD	3-4
--------------	-----

4. THE WORK STATION

THE L1 MOS WORK STATIONS	4-1
DISPLAY MODULE	4-1
KEYBOARD	4-3
ALPHANUMERIC WORK STATION	4-7
ELB 3684	4-8
MULTIPLEXER CONTROLLER (MUX)	4-9
ALPHANUMERIC AND GRAPHIC WORK STATION	4-10
WORK STATION EMULATORS	4-11
OLIVETTI PERSONAL COMPUTERS	4-11
VT100/VT200-LIKE TERMINALS	4-14

5. PRINTERS

6. MAGNETIC UNITS AND HOW TO USE THEM

DISKETTE UNIT	6-1
HOW TO USE AND HANDLE DISKETTES	6-4
HOW TO INSERT/REMOVE 5.25 INCH DISKETTES	6-6
HOW TO INSERT/REMOVE 8 INCH DISKETTES	6-7
HARD DISK UNITS	6-9
HOW TO USE THE SWITCH DEVICE	6-10
STREAMING TAPE UNIT	6-11
HOW TO USE THE STREAMING TAPE UNIT	6-12

HANDLING TAPE CARTRIDGES	6-12
HOW TO INSERT/REMOVE STREAMING TAPE CARTRIDGES	6-13
MAGNETIC TAPE UNIT	6-14
MOUNTING MAGNETIC TAPES	6-15
CONTROL PANEL	6-16
TAPE REMOVAL	6-17
ERROR SIGNALS	6-18
7. HOW SYSTEM OPERATES	
ACTIVATING THE SYSTEM	7-1
AUTODIAGNOSTICS	7-1
LOADING OF OPERATING SYSTEM	7-2
BACKUP SATELLITE	7-2
SYSTEM INITIALIZATION	7-3
MASTER TERMINAL	7-4
ERROR MESSAGES	7-5
CONNECTING/DISCONNECTING USERS	7-6
LOGIN	7-6
LOGOUT	7-8
MASTER WORK STATION (MWS)	7-8
SYSTEM DEACTIVATION	7-8
SHUTDOWN OPERATIONS	7-10
8. HOW TO USE THE KEYBOARD	
KEY SIGNIFICANCE	8-2

SHIFT key	8-2
CONTROL key	8-2
ESC Key	8-3
REPEAT, BACK SPACE, CARRIAGE RETURN, TAB Functions	8-4
CHANGE WINDOW and HARD COPY Functions	8-5
ENTER and SKIP Keys	8-5
Cursor Movement Keys	8-6
IL/IC, DL/DC Keys	8-7
EXIT, HALT PGM Keys	8-8
CLEAR/ERROR Key	8-9
CL.ER Key	8-10
CLEAR Key	8-10
ERASE/SEND Key	8-11
Function Keys	8-12

9. USING AN OLIVETTI PC AS WORK STATION EMULATOR

L1WSE EMULATOR	9-1
ACTIVATING THE L1WSE PROGRAM	9-3
WSELAN EMULATOR	9-5
ACTIVATING WSELAN PROGRAM	9-7
OLIEMU EMULATOR	9-9
ACTIVATING OLIEMU PROGRAM	9-12
ERROR MESSAGES	9-14

CONTEXT SWITCHING ERRORS	9-14
ASYNC2/ASYNC3 ERRORS	9-14
FILE TRANSFER	9-16
KEYBOARDS	9-19
KEYBOARDS 1 and 2	9-21
PB KEYBOARD WITH 105 KEYS	9-25
10. SHELL ENVIRONMENT	
THE FILE SYSTEM	10-3
SHELL COMMANDS	10-6
WORKING DIRECTORY COMMANDS	10-8
SETWDIR	10-8
SHWDIR	10-9
DIRECTORY COMMANDS	10-9
CLEARDIR	10-9
MKDIR	10-10
SHDIR	10-11
FILE, DIRECTORY, VOLUME COMMANDS	10-12
COPY	10-12
CPTREE	10-13
LIST	10-14
LS	10-16
MKALIAS	10-18
MORE	10-18
PRY	10-19

REMOVE	10-20
RENAME	10-21
SHALIAS	10-21
VOLUME COMMANDS	10-22
MKVOL	10-22
MNT	10-23
UNMNT	10-24
PRINT COMMANDS	10-24
LPQ	10-24
LPR	10-25
SPOOL	10-27
BATCH COMMANDS	10-28
BATCH	10-28
USER COMMANDS	10-29
SETPASSW	10-29
JOB CONTROL COMMANDS	10-30
KILL	10-30
RESUME	10-31
SUSPEND	10-31
RESERVED COMMANDS	10-32
FLDUMP	10-32
FLD	10-33
VCOMPACT	10-33
VOLSR	10-33

A. SELF-DIAGNOSTIC MESSAGES

ERROR DETECTION AND SIGNALLING	A-1
STEADY LIGHT CODES	A-2
FLASHING LIGHT CODES	A-3
MESSAGES ON DISPLAY SCREEN	A-4

B. SYSTEM MESSAGES

ERROR MESSAGES	B-1
IPL WARNINGS	B-5



1. INTRODUCTION

ABOUT THIS CHAPTER

Chapter 1 describes the general characteristics of the L1 MOS systems.

CONTENTS

HARDWARE STRUCTURE	1-2
SOFTWARE CHARACTERISTICS	1-2

INTRODUCTION

The Olivetti L1 MOS Line systems are modular products, with possibilities of configuring the system components in various ways and executing different types of application programs.



Fig. 1-1

The systems of the L1 MOS line are suitably used in business, scientific-technical, banking, office automation environments, as they are able to fulfill all the requirements that are typical of these environments.

The present L1 line consists of the M54, M64, M70 models which replace the previous M3X, M4X, M60 models. The models of the new line are more modular and more configurable than the previous ones.

HARDWARE STRUCTURE

As mentioned before, the L1 MOS systems can be configured in different ways in order to satisfy the various application needs. The possible configurations are:

- stand alone configuration
- cluster configuration
- local network

The stand-alone configuration consists of a single system with one or more work stations and connected, may be, to a Host Computer.

The cluster configuration has several satellite systems connected to a Master system. All satellites can support on-line activities or access the resources of the Master. This type of structure usually comprises a backup Satellite, which substitutes the Master in case of Master malfunctioning.

The local networks are an evolution of the cluster structure. They are characterized by a set of services (file server, line server, printer server, etc.) which can be accessed by any machine connected to the network independent of its physical location. The machines containing these services are known as "servers", and the machines using them are called "clients".

NOTE: The systems configured as indicated can communicate with one another via the geographical networks which solve the problem of long distances between systems.

SOFTWARE CHARACTERISTICS

The software provided for the L1 MOS line makes use of all the capabilities of the processor and of all the features offered by the connected peripheral units.

The Multifunctional Operating System (MOS) guarantees compatibility and integration amongst the various system models of the L1 MOS line. With its characteristics it can easily support highly-advanced requirements, such as:

- Defining several environments on one same system and on one same work station
- Multiprogramming, that is, running several programs at the same time.

- Multifunctioning, that is, handling several work stations on one same system
- Handling local and remote work stations
- Connecting Personal Computers
- Handling recovery and restart procedures
- Backing-up data stored on magnetic devices

The MOS operating system supports the following environments:

- SHELL, the general system environment
- DMS (Data Management System), a "Query Language" environment for handling disk files
- COBOL ICE, a business application and distributed data processing environment
- BASIC, a technical-scientific and simple business applications environment
- MTS (Modular Transactional System), a transactional environment
- Terminal emulator environments
- BEAM (Business Environment Application Monitor), a business programs monitoring environment
- OWS2 (Office Work Station), an environment integrating data processing and text processing functions
- ESE, an Olivetti P6060 minicomputer emulation environment

MOS comprises utility programs for:

- handling work stations (VISA)
- creating menus (T-FORM)
- sorting and merging files (SORT/MERGE)

and specific packages for graphics (PGU).

The programming languages used in the various environments are:

- BASIC
- COBOL
- FORTRAN
- PASCAL +

2. BASIC UNIT

ABOUT THIS CHAPTER

Chapter 2 describes the characteristics of the system's basic unit.

CONTENTS

M54 BASIC UNIT	2-1
THE BOARD RACK	2-2
MAGNETIC UNITS	2-3
M64 BASIC UNIT	2-4
THE BOARD RACK	2-5
MAGNETIC UNITS	2-6
M70 BASIC UNIT	2-7
THE BOARD RACK	2-9
MAGNETIC UNITS	2-10
CAB 7019	2-11
CAB 7018	2-12

BASIC UNIT

The basic unit is a module consisting of:

- main switch
- board rack
- built-in magnetic units
- system console
- power supply unit

Additional magnetic units can be connected to the basic unit of the M64/M70 systems.

M54 BASIC UNIT

M54 belongs to the same family of the M30/M34 systems. It is a desk-top model and can be placed comfortably on any working desk. It is a very compact unit and inside it has a nine-slot board rack. It is possible to connect work stations, printers, transmission lines and the ASD (Automatic Start Device), in self-standing version, to the M54 basic unit.

The M54 model can be configured as a stand-alone system, or as a satellite system in cluster configurations, or as server/client in local network environments. One or more work stations may be connected to it.

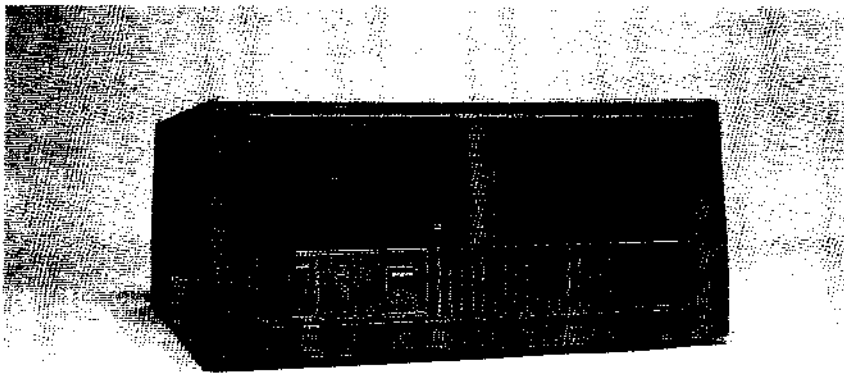

Fig. 2-1 M54 Basic Unit

THE BOARD RACK

The board rack is structured to contain up to 9 boards of the type "standard 3000". The boards are:

- **CPU.** Its main components are:
 - 16-bit microprocessor operating at 10 Mhz
 - 4K byte cache memory: a RAM memory communicating directly with the CPU for exchanging data without using up the system's main memory. This independence from main memory reduces the total processing time remarkably.
 - MMU (Memory Management Unit): handles the 128 memory segments logically addressed by the processor by defining the correspondence between physical addresses and logical addresses.
 - 32K byte ROM memory: contains autodiagnosics and the initial program loading software.
 - RS232 serial interface: is used for the asynchronous transmission/reception of characters from/to the line.

With regard to the M30/M34 models, the faster processor (10 Mhz instead of 4 and 8) and the cache memory increases processing power 1.6 times more than the M34's and 2.6 times more than the M30's.

- **Main memory.** Its capacity ranges from 512K bytes to 8 Mbytes. For memory capacities greater than 2 Mbytes, several boards must be mounted in the board rack. The memory boards available have the following capacities: 512K bytes, 1 Mbyte, 1.5 Mbytes, 2 Mbytes. The 1 Mbyte and the 2 Mbyte memory boards are of two types: with ECC (Error Corrector Circuit) and without ECC. ECC is a logic allowing correction of one single incorrect bit and signalling of a multiple error. It is not possible to configure ECC boards together with non-ECC boards.
- **Line controllers.** These are boards for handling the following types of resources:
 - Work stations: MUX controller for handling alphanumeric, b/w work stations, and the KDC controller with graphic expansion for handling alphanumeric, graphic, b/w work stations.
 - Magnetic units: controllers for ST506 or ESDI interface hard disks. The controllers for the removable devices must not be mounted in the board rack as they are already supplied with the magnetic unit.
 - Internal/external communication lines: various types of controllers like for the previous M30/M34 systems but without the SIC 3367 board.

MAGNETIC UNITS

The basic unit can house up to three magnetic units with 5.25 inch device in the following configurations:

- 1 or 2 diskette units with a capacity of 320K bytes or 1 Mbyte
- 1 ST506 HDU + 1 or 2 units with removable device
- 1 ESDI HDU + 1 or 2 units with removable device

The ST506 interface hard disks are supplied in different capacities as follows:

- 20 Mbyte hard disk
- 40 Mbyte hard disk
- 65 Mbyte hard disk

The ESDI hard disk is supplied in 140 Mbyte capacity only.

Any of the following removable devices can be used as hard disk backup:

- 320K byte or 1 Mbyte diskette unit
- 45/60 Mbyte streaming tape unit

The M54 basic unit cannot house two streaming tape units, but one only, and it is not possible to connect external magnetic units to the M54 system.

M64 BASIC UNIT

M64 is a stand-up type system, allocated comfortably at the side of a desk or generally placed anywhere inside an office. The physical characteristics of this basic unit are as follows:

- its structural form is narrow and lengthy
- its height does not exceed the height of a normal desk
- the console and removable devices are situated at the front so that they can be easily accessed
- the connectors for connecting external units (e.g. work stations, printers, serial magnetic units, etc.) are situated on the casing.

The M64 basic unit can be used as stand-alone module, or as master/satellite/backup satellite in cluster configurations, or as server/client in local networks. It may be composed of one or more work stations.

The basic unit is provided with an 11 slot board rack for connecting work stations, printers, communication lines and other RS232 peripheral units.

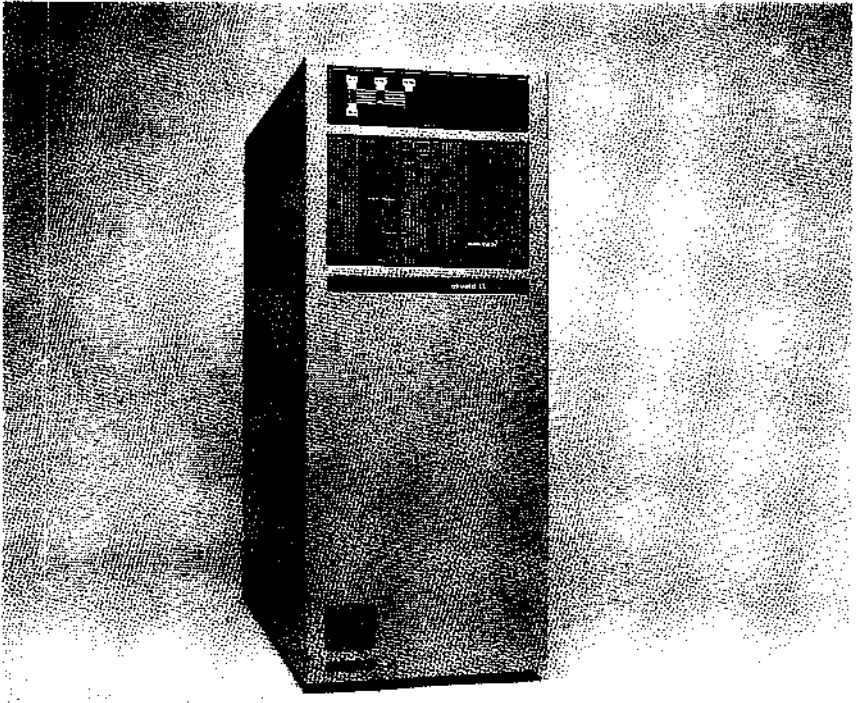

Fig. 2-2 M64 Basic Unit

THE BOARD RACK

The board rack is structured to contain up to eleven boards of the type "standard 3000". These are:

- **CPU.** Its main components are:
 - 16-bit microprocessor operating at 10 Mhz
 - 4K byte cache memory: a RAM memory communicating directly with the CPU for exchanging data without using up the system's main memory. This independence from main memory reduces the total processing time remarkably.
 - MMU (Memory Management Unit): handles the 128 memory segments logically addressed by the processor by defining the correspondence between physical addresses and logical addresses.

- 32K byte ROM memory: containing autodiagnosics and the initial program loading software.
- RS232 serial interface: for asynchronous transmission/reception of characters from/to console/line.

With regard to M40/M44 models, the faster processor (10 Mhz instead of 4 and 8) and the cache memory increases processing power by 1.6 times more than the M44's and 2.6 times more than the M40's. It is even slightly more than the processing power of the M60 monoprocessor model.

- **Main memory.** Its capacity ranges from 512K bytes to 8 Mbytes. For capacities over 2 Mbytes, it is necessary to mount additional main memory boards in the board rack. The capacities of the memory boards available are: 512K bytes, 1 Mbyte, 1.5 Mbyte, 2 Mbytes. The 1 Mbyte and 2 Mbyte memory boards are available in two different types: with ECC (Error Corrector Circuit) and without ECC. ECC is a logic allowing correction of one single incorrect bit and signalling of a multiple error. ECC boards cannot be configured together with non-ECC boards.
- **Controllers.** These are boards for handling the following types of resources:
 - Work stations: MUX controller for handling alphanumeric b/w work stations and the KDC controller with graphic expansion for handling alphanumeric and graphic b/w work stations.
 - Magnetic units: it is possible to use controllers for SMD, ST506, ESDI interface hard disks. The controllers for the removable devices are not inserted in the board rack but supplied together with the magnetic unit.
 - Internal/external communication lines: various types of controllers are used, the same ones for the previous M40/M44 systems but without the SIC 3367 board.

MAGNETIC UNITS

The basic unit can house up to four magnetic units with 5.25 inch device. The removable devices (max. 2) are housed in the front part of the basic unit, the fixed devices (max. 2) are placed at the back., as the operator doesn't have to access them frequently like the removable devices.

The following configurations are possible:

- 1 ST506/ESDI HDU + 1 or 2 removable devices

- 2 ST506 HDU + 1 or 2 removable devices
- 2 ESDI HDU + 1 or 2 removable devices

The types of ST506 interface hard disk units available are:

- 20 Mbyte hard disk
- 40 Mbyte hard disk
- 65 Mbyte hard disk

The ESDI hard disk unit is available in 140 Mbyte capacity only.

The removable units are used as hard disk backup and they are:

- 1 Mbyte diskette unit
- 45/60 Mbyte streaming tape unit

The M64 basic unit cannot house two streaming tape units, but one only.

In addition to the magnetic units built-in the basic unit, the M64 system can be provided with other magnetic units contained in specific cabinets then connected to the basic unit, that is:

- CAB 7019 expansion cabinet
- CAB 7018 expansion cabinet

M70 BASIC UNIT

The M70 system is a stand-up type unit comfortably placed at the side of a desk or anywhere inside an office. Its physical characteristics are:

- its structural form is narrow and lengthy
- its height does not exceed the height of a normal desk
- the console and removable devices are situated at the front so that they can be easily accessed
- the connectors for connecting external units (e.g. work stations, printers, serial peripherals, etc.) are situated on the casing.

The M70 basic unit can be used as a stand-alone module, or as master/satellite/backup satellite in cluster configurations, or as server/client in local networks. It may have one or more work stations connected and dispose of 1,2,3 CPUs (the number of CPU used transforms the system into a mono/bi/triprocessor type).

There are two types of basic unit: one consists of the basic cabinet with 11 board slots, the other type made up of the basic cabinet plus the CAB 7019 expansion cabinet which can house a sixteen-slot board rack. Work stations, printers, communication lines and other RS232 peripherals can all be connected to the basic unit.

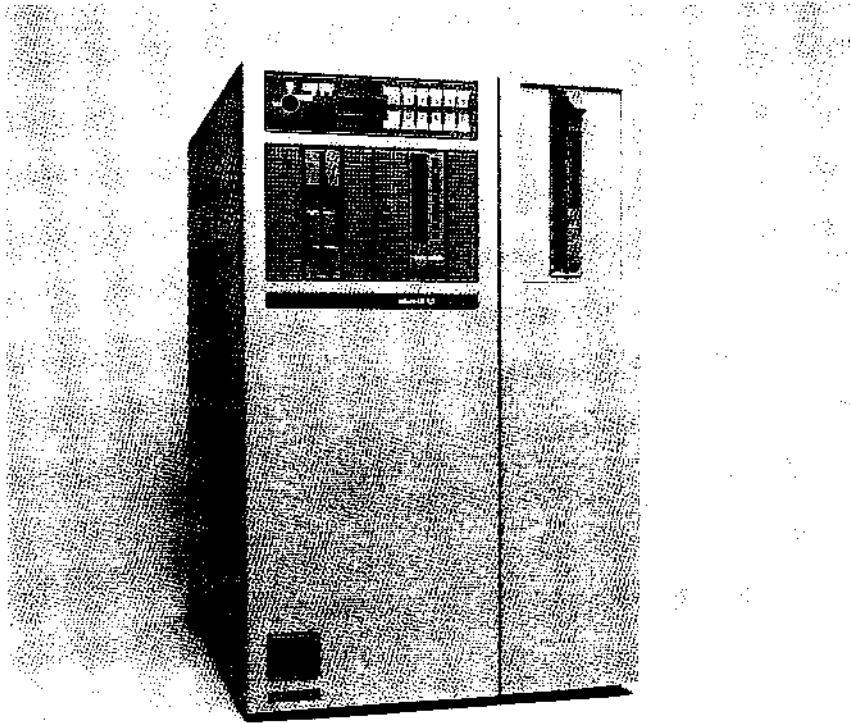

Fig. 2-3 M70 Basic Unit with Sixteen Board Slots

THE BOARD RACK

The board rack is structured to contain eleven or sixteen boards, at the most, of the type "standard 8000". The number of boards used (eleven or sixteen) depends on whether the basic cabinet is also associated to the CAB 7019 expansion cabinet, or not. The boards used are:

- **Main CPU.** Its main components being:
 - 16-bit microprocessor operating at 10 Mhz
 - 8K byte cache memory: a RAM memory communicating directly with the CPU for exchanging data without using up the system's main memory. This independence from main memory reduces the total processing time remarkably.
 - MMU (Memory Management Unit): handles the 128 memory segments logically addressed by the processor by defining the correspondence between physical addresses and logical addresses.
 - 32K byte ROM memory: containing autodiagnosics and the initial program loading software.
 - RS232 serial interface: for asynchronous transmission/reception of characters from/to console.

The faster processor of the M70 model 10 Mhz (instead of 8 of the previous M60 model), and the fact that the Cache Memory is contained on the CPU board results in an increase of system's processing capacity.

- **Auxiliary CPUs.** Besides the main CPU it is possible to mount other CPU boards(maximum two) in the board rack in order to transform the system into a biprocessor/triprocessor type.
 - **Main memory.** It can be configured with a capacity ranging from 2 to 8 Mbytes. This is done by mounting a number of boards in the board rack when the memory capacity is greater than 4 Mbytes. The boards are available in 2 to 4 Mbyte capacities. In the board rack there is the TCB board (Timing and Control Board) which incorporates the ECC logic (Error Corrector Circuit) for correcting a single wrong bit and signalling multiple errors, and is also used as memory refreshment.
 - **Controllers.** They are boards for handling the following resources:
 - Work stations: MUX controller for handling alphanumeric, b/w work stations, and the KDC controller with graphic expansion for handling alphanumeric graphic, b/w work stations.
-

- Magnetic units: it is possible to use controllers for SMD, ST506, ESDI interface hard disks. The controllers for the removable devices are not inserted in the board rack but supplied together with the magnetic unit.
- Internal/external communication lines: various types of controllers are used in the same way as for the previous M60s but without the SIC 3367 board.

MAGNETIC UNITS

The basic unit can house up to four magnetic units with 5.25 inch device. The removable devices (max. 2) are housed in the front part of the basic unit, the fixed device units (max.2) are placed at the back as they do not need to be accessed by the operator.

The possible configurations are:

- 1 ST506/ESDI HDU + 1 or 2 removable device
- 2 ST506 HDU + 1 or 2 removable device
- 2 ESDI HDU + 1 or 2 removable device

The following types of ST506 interface hard disk unit are available:

- 20 Mbyte hard disk
- 40 Mbyte hard disk
- 65 Mbyte hard disk

The ESDI hard disk unit is available in 140 Mbyte capacity.

The removable units used as hard disk backup are:

- 1 Mbyte diskette unit
- 45/60 Mbyte streaming tape unit

The M70 basic unit cannot house two streaming tape units, but one only.

In addition to the magnetic units built-in the basic cabinet, the M70 system can be provided with other magnetic units contained in their own cabinets CAB 7019/CAB 7018.

CAB 7019

It can be connected to M64/M70 systems and can house an 8 inch diskette unit with 1 Mbyte capacity powered by the same power supplier of the basic unit.

When the cabinet CAB 7019 is connected to the M70 system it can be used as a magnetic module as well as an expansion module of the basic unit to provide a sixteen-slot board rack.

The lower part of CAB 7019 may contain an expansion power supplier which supports the basic power supply unit when configurations require it.

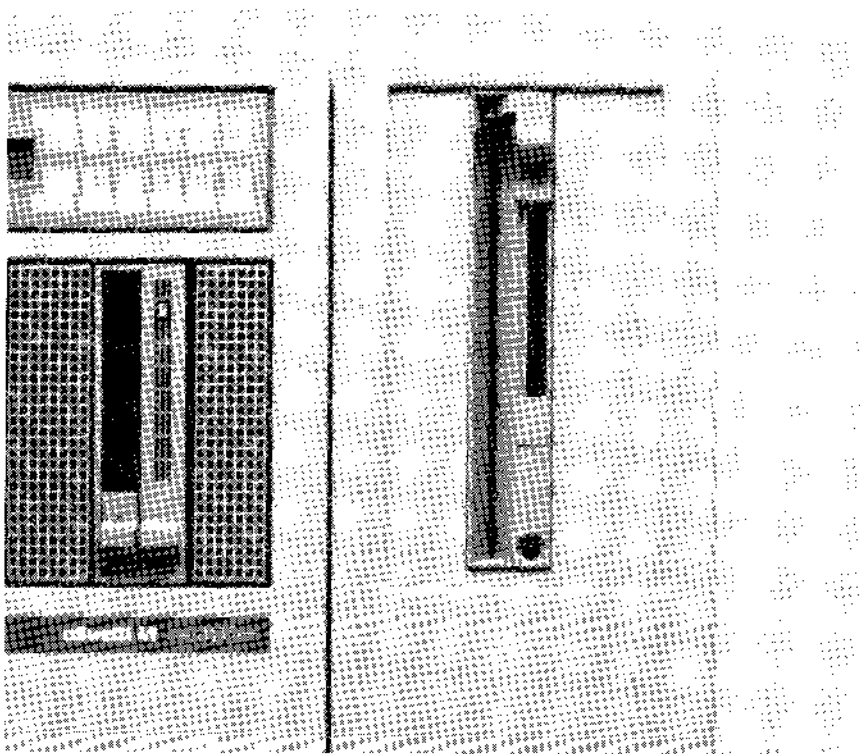

Fig. 2-4 CAB 7019 Connected to M70

CAB 7018

CAB 7018 has its own structure and has two sectors to house magnetic units:

- the upper sector can house a 40 Mbyte MTU
- the lower sector can house one or two SMD interface hard disk units which can be shared, optionally, by two different systems.

A system can support only one MTU.

The hard disks contained in the lower sector of the cabinet may have the following capacities: 60, 120, 275 Mbytes.

The hard disks can be mounted in CAB 7018 only if there are no fixed disk in the basic unit, as the three types of hard disk available (ST506/ESDI for the basic unit, SMD for CAB 7018) are not compatible with one another.

If two hard disks are used, then the possible configurations are:

- two 60 Mbyte HDU
- two 120 Mbyte HDU
- one 60 Mbyte HDU + one 120 Mbyte HDU
- two 275 Mbyte HDU

The 60 and 120 Mbyte hard disks use the same controller.

The hard disks can be shared by two different systems provided they are supplied with the appropriate switch device: there are two DUAL PORT switch devices, one for 60/120 Mbyte hard disks and the other for 275 Mbyte hard disks.

3. CONSOLE

ABOUT THIS CHAPTER

Chapter 3 describes the characteristics of the system console and how to use it. The information given in this chapter is particularly valuable to the system manager who is the person that is mainly concerned with the console. This chapter may also be of interest to work station users.

CONTENTS

BASIC CONSOLE	3-1
EXTENDED CONSOLE	3-2
THE KEYBOARD	3-4

CONSOLE

The console is the basic unit component which an operator uses to dialogue with the system.

There are two types of console:

- basic console (for M54/M64 systems)
- extended console (for M64/M70 systems)

BASIC CONSOLE

The basic console consists of three operator interface devices:

- ISL switch
- reset push-button
- diagnostic display with seven segments (one digit)

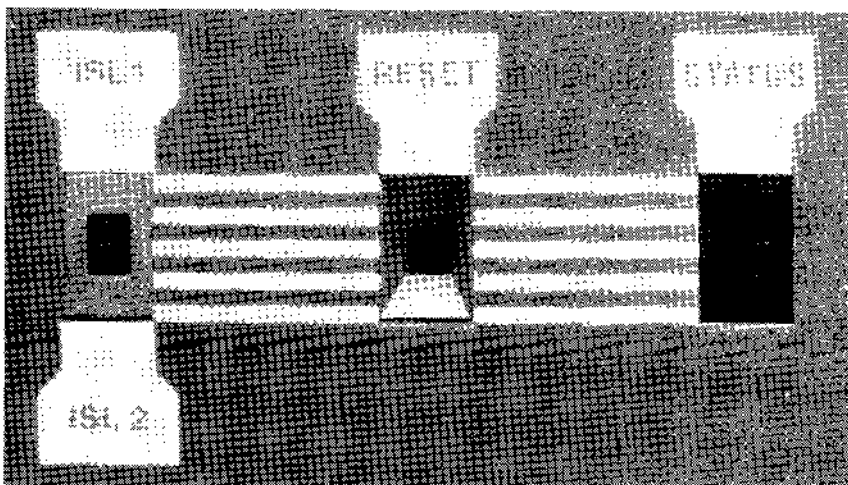

Fig. 3-1 M64 Basic Console

ISL is a switch which tells the system if the IPL (Initial Program Loading) phase is made with a fixed device (ISL 1) or a removable device (ISL 2).

When reset is pressed, the system returns to the start-up state and repeats the two initial phases: autodiagnosics and IPL.

Using the diagnostic display the system informs the operator that the whole system is powered up (in fact, the first component powered up as soon as the main switch is turned on, is the console) and signals any errors encountered during autodiagnosics or run-time.

EXTENDED CONSOLE

The extended console is provided with a RAM memory containing all the necessary information to operate on it (e.g. the passwords of the various functions, etc.). This memory has a power-up battery which provides power, when the console is off, for about two hundred days. In this way information stored in memory can be recovered even when the console is inoperative for long periods of time up to the indicated days.

The operator interface devices are:

- power on key
- power on led (PW)
- power supply units led (ALI)
- diagnostic led (NO GO)
- display
- keyboard

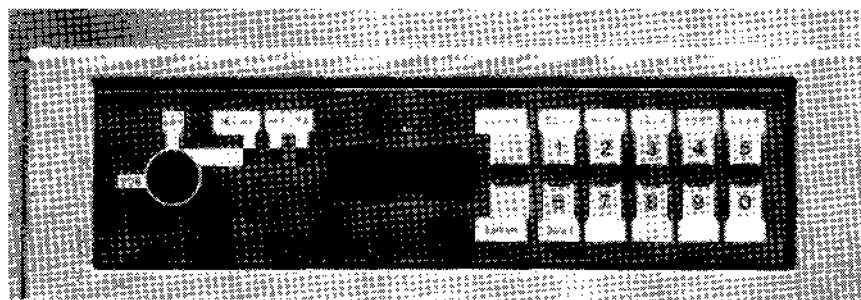

Fig. 3-2 Extended Console

The power on key has two positions, with main switch on:

- STAND-BY position: the console is the only one powered on, while the rest of the system is off.
- RUN position: the whole system is powered on.

The procedure RUN - STAND-BY - RUN is very significant in that it produces a system reset (on the extended console there is no reset button).

The meaning of the console leds is:

- The power-on led tells the operator that the console is powered on (power-on key in STAND-BY position).
- The power supply units led tells the operator that the system is powered on (power-on key in RUN position) and the power supply voltages are correct.
- The diagnostic led, with power-on key in RUN position, is usually off. But it can change as follows:
 - it comes on when the system has not been able to perform the IPL phase and the relevant error code appears on the console display.
 - it flashes when the firmware has encountered a non-blocking error.

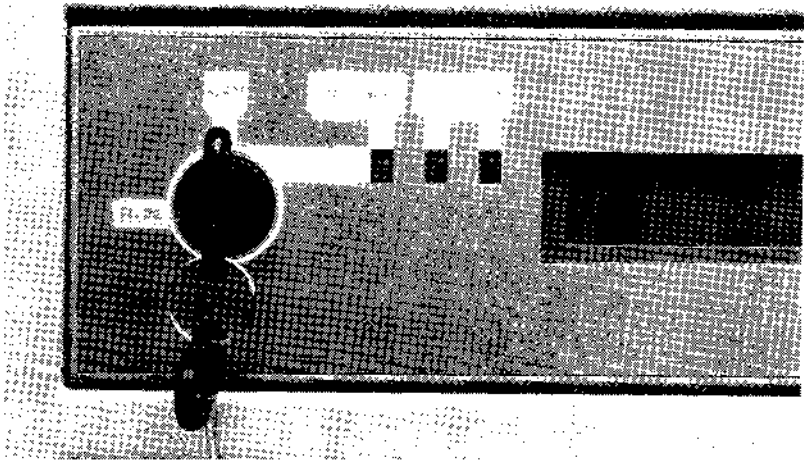

Fig. 3-3 The Power-On Key and the Leds

The display consists of six alphanumeric digits. The system uses the console display to indicate, in the form of messages, any malfunctioning found during console and system autodiagnosics. It is also used for system-operator interactive dialoguing to activate console functions.

THE KEYBOARD

The keyboard of the extended console consists of ten numeric keys and two special keys. The special keys are:

- The **CLEAR** key: for deleting previous operations requested through the console.
- The **ENTER** key: which confirms the function selected and the data entered (e.g.: the password associated to the function).

The numeric keys are used for entering functions and parameters. Two types of functions can be requested through the keyboard that is:

- Mnemonic functions: activated by using one single numeric key and by entering the password previously assigned to the mnemonic function involved. Each function is provided with a numeric code, which corresponds to the key that activates the function, and a mnemonic code, written in correspondence with the activation key.
- Coded functions: activated by using two numeric keys and by entering, not necessarily, the password (the entering of the password depends on whether the functions are protected or not). Each coded function is provided with a numeric code, which corresponds to the pair of keys activating it, and no mnemonic code.

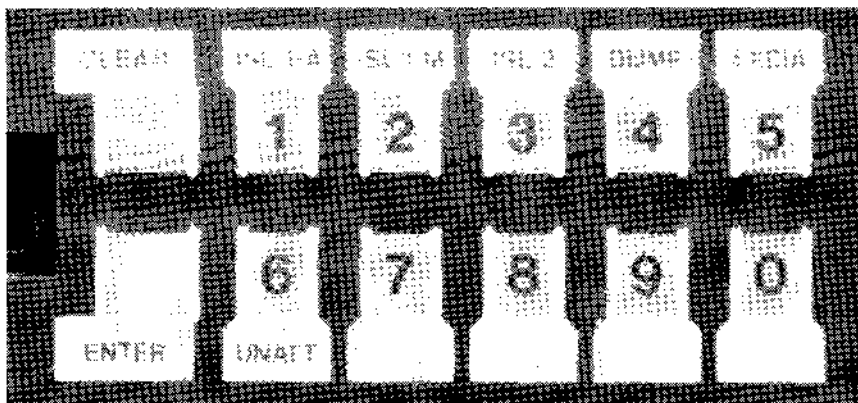

Fig. 3-4 The extended Console Keyboard

For all the functions that require a password, the request for the password appears on the console display as follows: **TypPwd**

Mnemonic Functions

Numeric codes, mnemonic codes and functions description are given below.

1. **ISL 1-A:** tells the system that the default operating environment is loaded at system power-on time from a fixed device. Function accepted with power-on key in STAND-BY position.
2. **ISL 1-M:** tells the system that the operating environment is to be selected from an environment menu and loaded from a fixed device. Function accepted with power-on key in STAND-BY position.
3. **ISL 2:** tells the system that the IPL phase is performed from a removable device. Function accepted with power-on key in STAND-BY position.
4. **DUMP:** tells the system to make a physical copy of the memory content on a 5.25 inch or 8 inch diskette; the type of diskette to be used is selected through a menu. The Dump function can be carried out only when the power-on key is positioned on RUN.
5. **EXDIA:** tells the system to change the diagnostic state. Function accepted with power-on key positioned on STAND-BY. After entering the password, the function state is indicated (ON: means extended diagnostic activated; OFF: means non-extended diagnostics); to change the function state, press **5** again followed by **ENTER**.
6. **UNATT:** indicates that the system can be tele-powered-on/tele-powered-off via switched or dedicated line (Unattended mode). This function also permits the system to be powered-off via software command. After entering of password, the state of the function is shown (ON: function activated; OFF: function deactivated). To change the function state, press **6** again followed by **ENTER**.

After having activated the UNATT function, the power-on key must be turned on STAND-BY, if not already in that position. Then **UNATT** appears on display.

Codes 7-8-9-0 are not assigned to any mnemonic code. Some are used when the telediagnostic feature is available.

Protected Coded Functions

These functions require entry of password. Their numeric codes and corresponding descriptions are given below:

- **02:** this command causes the system to remain on even when the power-on key is in STAND-BY. Command activated automatically if command 6 has been selected previously. The system indicates that it has accepted the function by displaying: **AUTOFF** .
- **03:** deletes function 02 previously selected.
- **04:** activates the "non maskable interrupt".
- **05:** sets the system clock. This command asks you for the year, the month, the day of the week, the day of the month, the time in hours and minutes. The year, the day of the month, the time (hours and minutes) must be entered in numeric form (two digits for the year and day of the month, four for the time); whereas the month and the day of the week are to be entered in alphabetical form (the first three characters of the name in English).

If the system clock is already set, this command displays the current data. The clock data can be modified as desired by inserting the corresponding data in numeric form (month: 01 for January, 02 for February, etc.; days of the week: 01 for Sunday, 02 for Monday, etc.).

- **06:** sets the system power-on time in the weekly calendar. The system is not powered-on via the line, as for the Unattended function, but the machine powers-on itself. After the password is confirmed, the calendar state is then displayed (ON: calendar activated; OFF: calendar deactivated). To program the calendar with the desired system power-on days and time, press **1** then **ENTER** .

Now the system is set for calendar programming and a two-digit code appears on display indicating the day of the week (01 for Sunday, 02 for Monday, etc.). At this point you have to reply with four digits indicating the power-on time, that is hour and minutes (e.g., 0830 meaning 8.30 a.m., 1730 meaning 5.30 p.m., and so on). Before pressing **ENTER** to confirm the time indicated, you have to press **1** if you want the function to be actually activated in that day, or **0** for the opposite. In this way there is the possibility to use the feature for all the days of the week or for some days only.

- **10:** reads the "Error Logging" register relevant to the ALIUP signal. This signal is an indicator of the power voltage supplied. This signal is enabled when the voltage is within the limits of tolerance, disabled when it is not.

The ALIUP "Error Logging" register contains the number of times the ALIUP signal has been disabled without system powering-off. Reasons for it to become disabled are sometimes due to short circuit conditions, or excess of output voltage from the power supply unit.

- **11:** reads the "Error Logging" register relevant to the DATE signal. This signal is an indicator of the power supply unit temperature: the DATE signal is enabled when the temperature is within the permissible limits and becomes disabled when not.

The DATE "Error Logging" register contains the number of times the DATE signal has become disabled.

- **13:** reads the "Error Logging" register relevant to the PWUP signal. This signal is an indicator of the voltage supplied by the power supply unit. It is enabled if the voltage is sufficient for correct power supply unit operating conditions; it becomes disabled if not.

The PWUP "Error Logging" register contains the number of times in which, after a disabled condition, the PWUP signal has been immediately enabled without causing the power supply unit to halt.

- **00:** reads all the "Error Logging" registers. After having entered the password, the system asks for the code of the register to read: 10 for ALIUP, 11 for DATE, 13 for PWUP. After having indicated the register code, there appears on display the name of the register with the number of events that has enabled it. Up to ninety nine events are counted.
- **01:** sets the "Error Logging" registers to zero. The enabling procedure is the same as the one for function "00".

Non-protected Coded Functions

These functions do not require the entry of the password. Their numeric codes and relevant description are:

- **20:** allows you to enter or modify the password with which it is possible to access protected mnemonic and coded functions. It requires the power-on key to be positioned on STAND-BY. After selecting the desired function, the system asks for the numeric code of the function to be protected.

If there is no previous password or the console memory has been cancelled, you are asked to turn the power-on key as follows: STAND-BY - RUN - STAND-BY (message **KeyCom**). After having turned the key as indicated above, you are given the following message **TpNpwd** which asks you to enter the password. Then you

are given the message **RpNpwd** which asks you to repeat the entry of the password.

If there is already a password and you want to change it, you are asked to indicate the old password (message **TpOpwd**). Then you are asked to enter the new password (message **TpNpwd**) followed by the request to repeat the entry of the new password (message **RpNpwd**).

The password must be a six-numeric-character string. If you enter six zeroes you delete the protection. If you make an error while defining the password, you must abort the function by using the **CLEAR** key.

- **21:** supplies board rack diagnostic data. The first data displayed belongs to the first board (the lower board) mounted in the board rack. By pressing **ENTER** , the diagnostic data of the second board is displayed. Continue pressing **ENTER** , so that the diagnostic data of all the boards mounted in the board rack will be displayed to you. Each board data is displayed for ten seconds, at the most, and if after that time you have not pressed the **ENTER** key, the system automatically exits from this function.

The type of diagnostic data displayed for each board is:

- type of board
- slot number in hexadecimal form
- result of the board diagnostics: OK = positive diagnostics; KO = blocked controller; WR = controller not blocked but is becoming degraded, a deeper analysis is necessary.
- **22:** displays the date, set previously with function 05, for three consecutive cycles. Each cycle lasts for four seconds and the date is displayed as follows: Year/Month/Day of the week/Day of the month/Time (hours and minutes).
- **99:** displays console status data. A message is displayed, scrolled from right to left, indicating the state of the various functions.

4. THE WORK STATION

ABOUT THIS CHAPTER

Chapter 4 describes the characteristics of the work stations connected to the system.

CONTENTS

THE L1 MOS WORK STATIONS	4-1
DISPLAY MODULE	4-1
KEYBOARD	4-3
ALPHANUMERIC WORK STATION	4-7
ELB 3684	4-8
MULTIPLEXER CONTROLLER (MUX)	4-9
ALPHANUMERIC AND GRAPHIC WORK STATION	4-10
WORK STATION EMULATORS	4-11
OLIVETTI PERSONAL COMPUTERS	4-11
VT100/VT200-LIKE TERMINALS	4-14

THE WORK STATION

The work station is the user/system interface for carrying out normal working activities.

How many work stations can be connected to a single system depends on the configuration of the basic unit board rack.

There are two types of work stations: the L1 MOS work stations and the work stations emulating the L1 MOS work stations.

THE L1 MOS WORK STATIONS

The L1 MOS work stations consist of a: monochrome display module, keyboard, and the electronic box if necessary.

Depending on the kind of operations carried out, there are alphanumeric work stations and alphanumeric/graphic work stations.

DISPLAY MODULE

The following alphanumeric and alphanumeric/graphic display modules are available:

- 9 inch, trivalent, monochrome, alphanumeric display module (DSM 3619), with screen capacities of 520, 1000, 2000 characters (selectable).
- 15 inch, bivalent, monochrome, alphanumeric display module (DSM 3615), with screen capacities of 1000 or 2000 characters (selectable).
- 15 inch, monochrome, alphanumeric/graphic display module (DSM 3616). Screen capacity depends on use: 2000 characters when used as alphanumeric display module; 640 x 400 pixels when used as graphic display module.

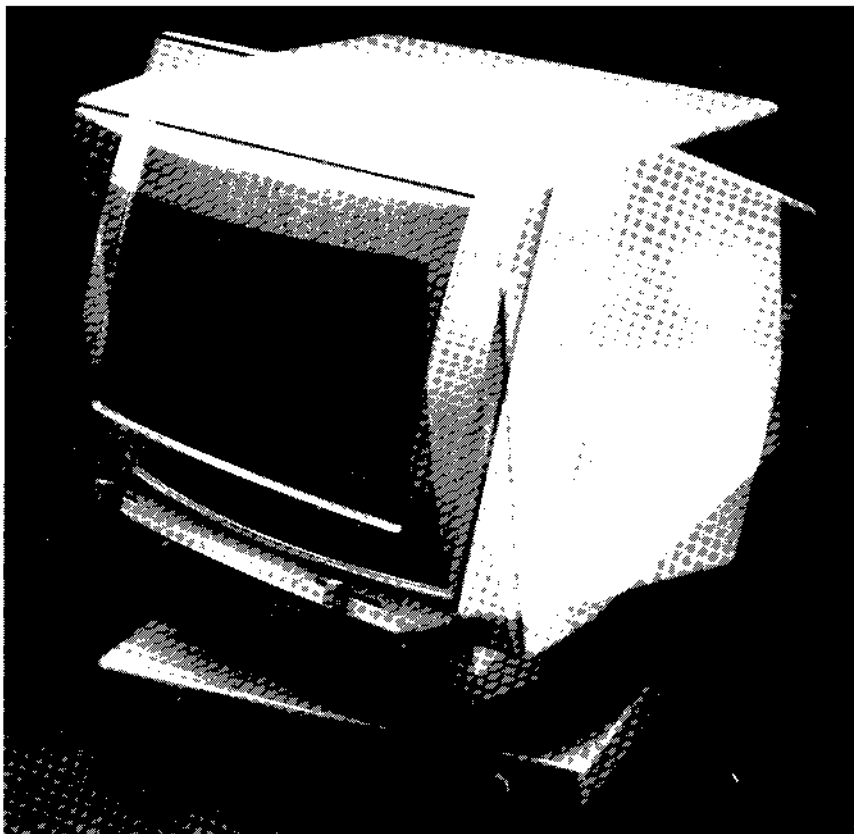

Fig. 4-1 15-inch Monochrome Display Module

In graphic display modules used for scientific applications, the alphanumeric and graphic characters are displayed simultaneously but they are controlled independently.

All display modules are mounted on a base that permits screen rotation and tilting and are provided with an anti-glare filter to minimize eye fatigue. A manually operated brightness and contrast control is provided for adjustment to different lighting environments.

Visual attributes are:

- normal intensity
- high intensity
- flashing

- underlining
- reverse
- absolute dark.

In addition to the visual attributes, special graphic characters are also available for creating format grids used for data entries and inquiries.

KEYBOARD

The work station keyboard is designed particularly for ease of use (low profile, adjustable angular inclination, etc.). It is composed of two distinct sections:

- alphanumeric section
- numeric + function keys section

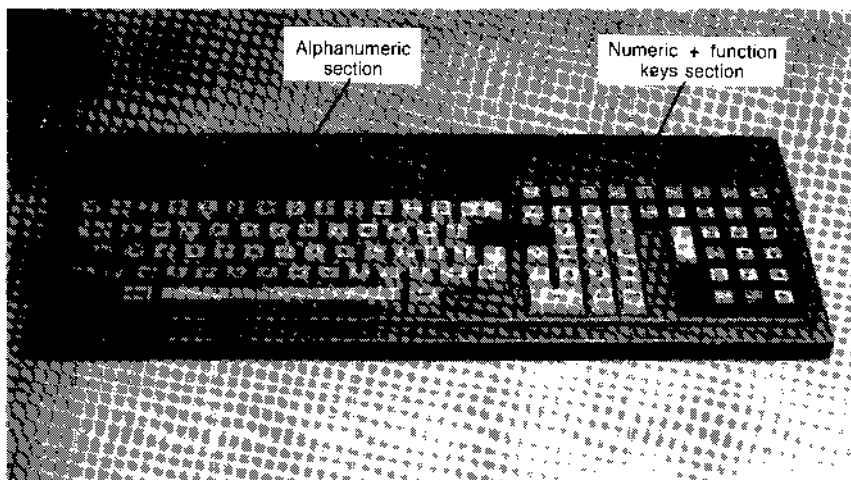

Fig. 4-2

The keyboard is available in different national versions. Each version is provided with its corresponding national characters. The table below shows, for each nation, the graphic equivalents of the indicated ASCII codes.

ASCII CODE		GRAPHIC EQUIVALENTS														
DECIMAL	HEXADECIMAL	USA	ITALY	FRANCE	GREAT BRITAIN	GERMANY (1)	GERMANY (2)	SPAIN	PORTUGAL	DENMARK	SWEDEN FINLAND	NORWAY	FRENCH SWITZERLAND	GERMAN SWITZERLAND	GREECE	JUGOSLAVIA
35	23	#	E	E	E	#	#	E	#	E	#	E	E	E	E	#
36	24	S	S	S	S	S	S	S	S	S	□	S	S	S	S	□
64	40	ø	é	à	ø	ö	ö	ö	ö	·	ø	·	ö	ö	ø	ö
91	5B	l	o	o	l	X	X	i	Ä	Æ	X	Æ	ä	ä	l	ø
92	5C	\	ç	ç	\	Ö	Ö	Ñ	ç	Ø	Ö	Ø	ç	ç	\	É
93	5D	j	é	é	j	ü	ü	ç	Ö	Ä	Ä	Ä	é	é	j	z
96	60	·	ü	·	·	·	·	·	·	·	·	·	·	·	·	z
123	7B	{	à	é	{	ä	ä	°	ä	æ	ä	æ	ä	ä	{	ø
124	7C		ö	ü		ö	ö	ñ	ç	ø	ö	ø	ö	ö		é
125	7D	j	é	é	j	ü	ü	ç	ö	ä	ä	ä	ü	ü	j	z
126	7E	-	l	·	·	B	B	·	o	·	·	·	é	é	·	z

Fig. 4-3

It is possible to use keyboards that are specific for each different application environment (that is, BC/DP and ST) or a single multifunctional keyboard which allows to operate in all environments.

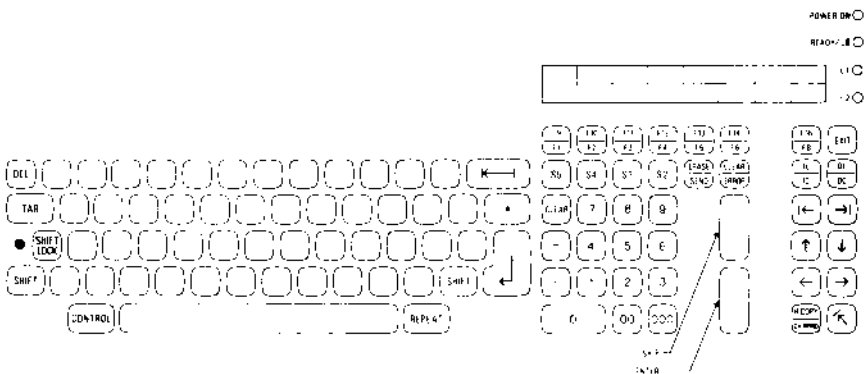

Fig. 4-4 Business Keyboard (BC/DP Environments)

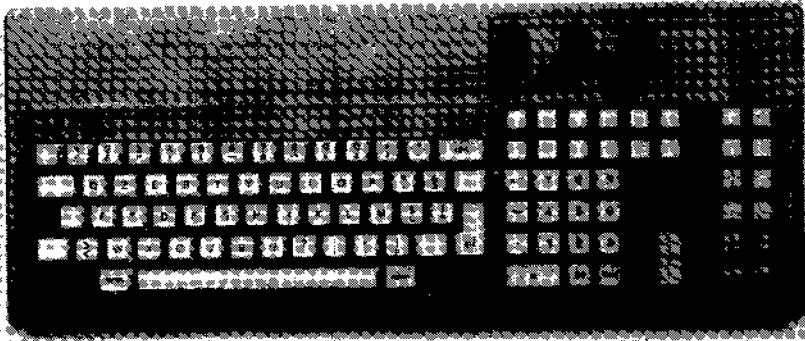

Fig. 4-7 Business Keyboard with Key Locks

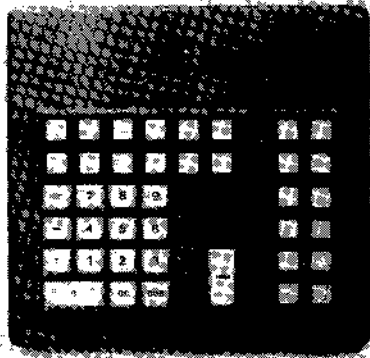

Fig. 4-8 Business Keyboard in Reduced Version

See chapter eight of this manual for information on how to use the keyboards.

ALPHANUMERIC WORK STATION

The alphanumeric work station is connected to the basic unit through the MUX controller, housed in the basic unit, and is comprised of:

- alphanumeric monochrome display module (DSM 3615 or DSM 3619)
- multifunctional keyboard
- ELB 3684 minibox

Both RS232 interface peripherals and TTL interface peripherals can be connected to the alphanumeric work station through the ELB 3684 minibox (in this case the ELB 3684 must be provided with an appropriate expansion board).

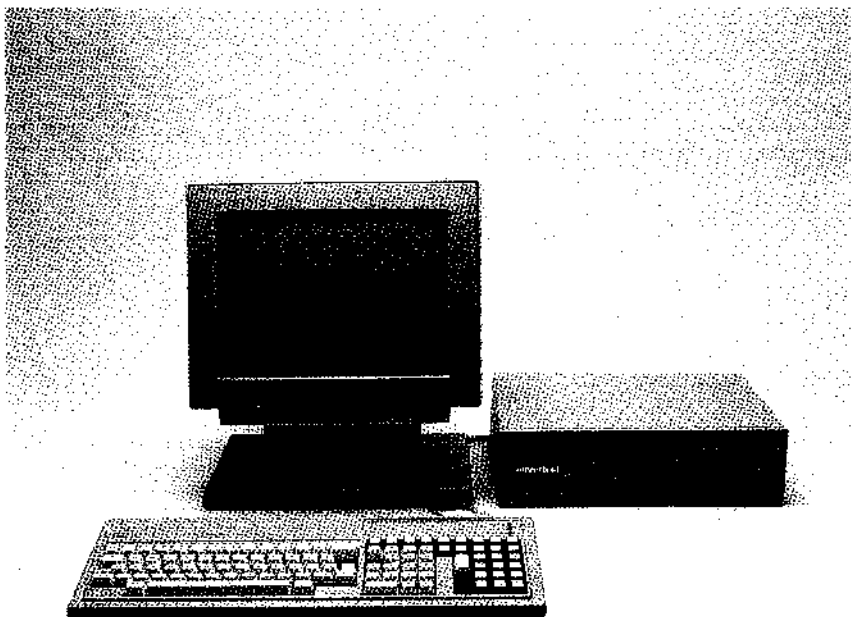

Fig. 4-9 Alphanumeric Work Station

ELB 3684

The ELB 3684 minibox is made up of:

- a microprocessor
- 4K byte RAM memory
- 32K byte ROM memory
- display screen refreshment buffer (4K bytes)
- display/keyboard, printer and auxiliary peripherals serial interfaces
- L1, Current Loop or RS232 serial interface
- trivalent display controllers for 9 inch, 15 inch monitors
- TTL peripherals interface (optional)

The minibox serves to connect work stations situated at various distances from the basic unit. If the work stations are at a distance of 1000 meters or less from the basic unit, then the Current Loop interface can be used. Beyond the 1000 meter distance, the connection is obtained by using the RS232 interface with modem and possibly with error controller and/or statistical multiplexers.

ELB 3684 is compatible with ELB 1381/1382. Because of this, they can be used together on the same system for connecting different work stations.

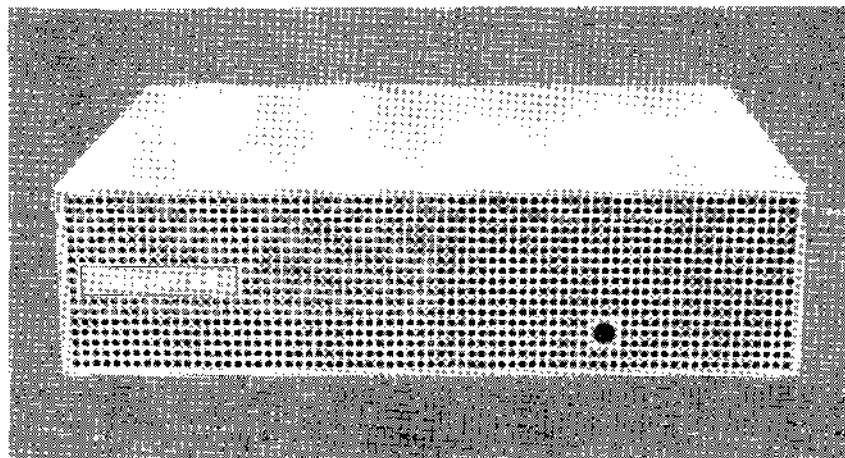

Fig. 4-10 ELB 3684 Minibox

MULTIPLEXER CONTROLLER (MUX)

The multiplexer controller is a four channel controller which can connect up to four work stations, unlike the KDC controller (see alphanumeric and graphic work station) which can connect a single work station only.

Besides alphanumeric work stations, MUX can connect printers and general Input/Output devices (banking peripherals, modems, plotters, tablets, etc.).

The 4 MUX channels can operate at different speeds independent from the type of interface used, provided the overall transfer rate limit of 38400 bit/sec is respected (the different speeds are software programmable ranging from 300 to 19200 bauds). MUX interfaces are: RS232 and Current Loop.

There are two types of MUX controllers: non-remote MUX and remote MUX.

Non-Remote MUX

The 4 channels of this type of controller can use the following interfaces:

- 2 RS232 + 2 Current Loop
- 1 RS232 + 3 Current Loop
- 4 Current Loop

The following types of connection are available:

- **Local RS232:** for alphanumeric work stations, VT100/VT200 like terminals, Personal Computers, peripherals. The maximum distance covered by this type of connection is 15 meters.
- **Remote RS232:** similar to the Local RS232 but used with modem to cover longer distances without limits.
- **Current Loop:** for alphanumeric work stations, Personal Computers, VT100/VT200 like terminals

Remote MUX

Unlike the non-remote MUX, this type of controller is used for Remote RS232 connections with "error controller/statistical multiplexer" devices in addition to modems.

The advantage of using these devices is the possibility of controlling the "system-work station" line, so that any possible transmission errors are immediately corrected.

Unlike the non-remote MUX, here the 4 channels can use only the following interfaces: 2 RS232 + 2 Current Loop. The Remote RS232 connection always requires, besides modems, the error controllers or the statistical multiplexers.

ALPHANUMERIC AND GRAPHIC WORK STATION

Alphanumeric and graphic work stations are connected to the basic unit through the KDC controller with graphic expansion and mounted on the system's basic unit.

Work stations are connected directly (for distances of 5 meters or less) or the ELB 1381/1382 minibox must be used for distances between 5 and 100 meters. Work stations placed at distances over 100 meters cannot be connected.

The display module used is the DSM 3616 (alphanumeric/graphic monochrome display module). The keyboard is any of the ones available (the scientific keyboard is particularly suitable for graphic applications).

When this work station is used alphanumerically, it can connect all the work station peripherals indicated in the next paragraph. When used graphically, it connects graphic peripherals such as: graphic printers, plotters, tablets, etc., via RS232.

Work Station Peripherals

The system can be easily customized according to individual requirements by associating work stations to the following optional peripherals (max 4 per every work station). The optional peripherals are connected to the ELB 1382/3684 via TTL or RS232 interface.

- Work station printer
- Badge reader (MBR 1932)
- Badge and passbook reader/writer (MRW 1810)
- Badge reader/writer (BRW 1822)
- Personal identification module (PIN Pad 1440)

- Bank/post office documents reader (ML 700)
- Bank/post office documents reader/encoder (LP 700)
- High-speed banknotes dispensing module (CA 2000)
- CAT 3300 self service terminal
- Signature visual control device

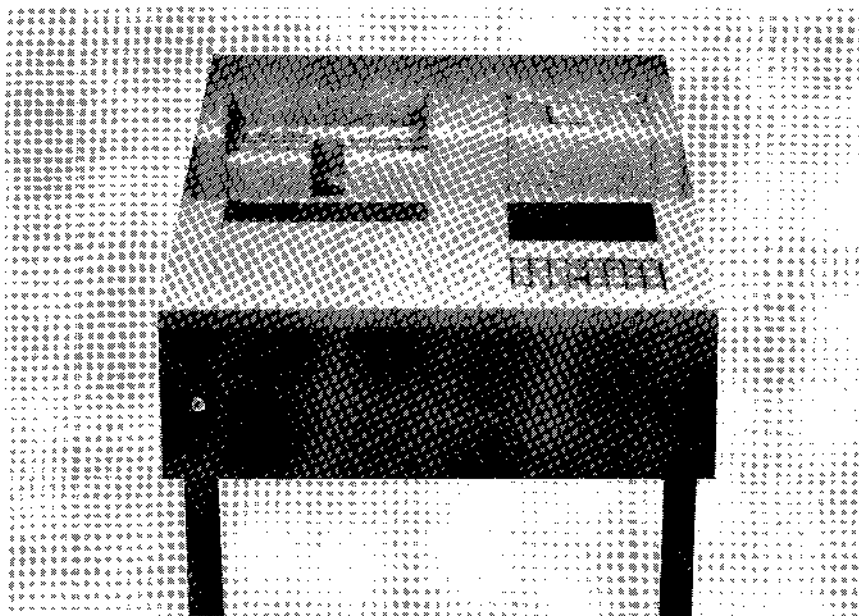

Fig. 4-11 CAT 3300 Terminal

NOTE: Information on how to use these modules is found in the relevant module manuals.

WORK STATION EMULATORS

At present the work station emulator family consist of Olivetti Personal Computers (PC) and the VT100/VT200-like terminals.

OLIVETTI PERSONAL COMPUTERS

The Olivetti Personal Computers can also be used as L1 MOS work stations provided they are supplied with the correct software. In emulation

environment, the PCs emulate the L1 MOS work station and supply additional features (e.g.: the PCs can handle a colour display module and graphics capabilities when emulating work station via MUX).

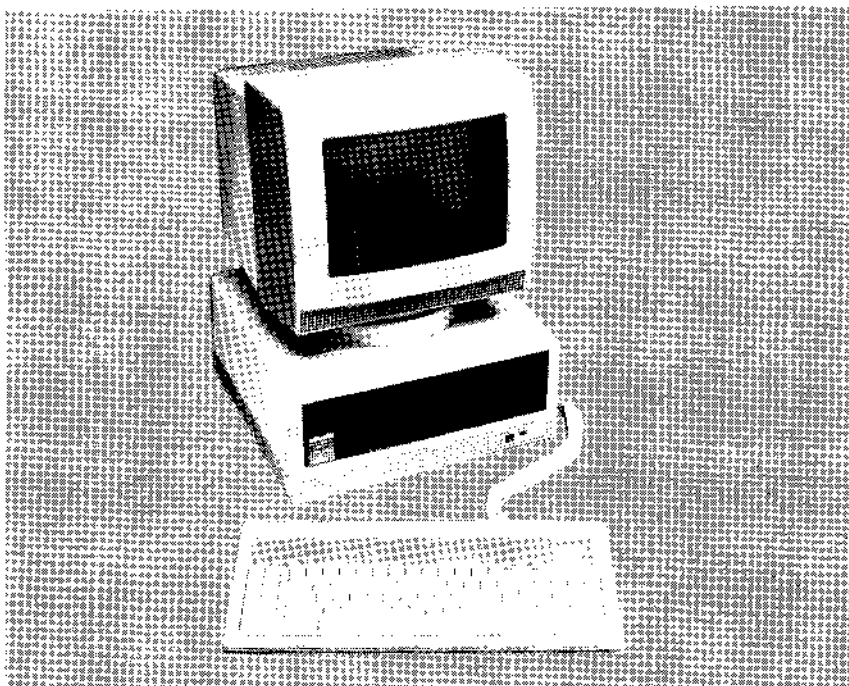

Fig. 4-12 M24 Personal Computer

An Olivetti PC connected to the L1 MOS system operates as an alphanumeric and graphic, black/white or colour work station. If it uses a colour display in emulation environment, then it can utilize the EGC display controller in place of its local one, to have access to additional graphic features.

The dialogue between the Personal Computer and the system can be:

- transparent
- via PORTS
- via MUX protocol

From a software point of view, there are three emulators for the three type of dialogue used:

- L1WSE: for transparent dialogue
- WSELAN: for dialogue via PORTS
- OLIEMU: for dialogue via MUX protocol

The L1WSE and WSELAN emulators emulate the alphanumeric/graphic work station via KDC; the OLIEMU emulates the alphanumeric work station via MUX with possibility of handling graphics.

The PC application environments are:

- Shell
- COBOL ICE
- interpreted BASIC
- DMS
- MTS
- BEAM
- ESE

Any other application written in COBOL, BASIC, FORTRAN, PASCAL + , as well as graphic functions, VISA package functions, and MOS utility programs can also be used.

How to Connect an Olivetti PC to L1

L1WSE and OLIEMU handle serial interface connections (RS232 or Current Loop), whereas WSELAN handles OLILAN local network connections.

Connection via RS232 can be local or remote with modem. The interfaces to be used are: for L1, one of the two contained in the non-remote MUX; for PC, the one of the RS232 board or the CPU's. OLIEMU also handles remote connections with modem and "error controller/statistical multiplexers" via remote MUX on L1.

Current Loop connection is obtained by using the following interfaces: for L1, any interface contained on MUX; for PC, the Current Loop board interface.

PC is connected to L1 in local network via RS232 or by using Omninet/Ethernet boards. How this type of connection is performed is written on the manual: "OLILAN Local Area Network Code 4021820 Q".

For more information on Olivetti PC used as L1 MOS emulator, read chapter nine in this manual.

VT100/VT200-LIKE TERMINALS

The L1 MOS systems have the possibility of connecting terminal-based work stations, known as VT100/VT200-like, which are very similar to the "Digital Research" VT100 or VT200 terminals.

The rules to be followed for connecting L1 MOS to VT100/VT200-like terminal are:

- L1 MOS system can be connected via MUX controller
- the VT100/VT200-like terminal must be connected through its own serial interface (RS232 or Current Loop).

Connection can be direct, using modem or Current Loop (depending on the distance between the two units).

From the software point of view, the MOS operating system must be provided with the serial interface driver and be configured to handle a VT100/VT200-like terminal based work station.

The configurable environments on a VT100/VT200-like terminal are Shell and MTS.

Applications written in FORTRAN and PASCAL + languages can also be used.

Limitations are:

- no graphic and colour functions
- no bivalence and trivalence display module functions
- no multiple windows
- no calls to Shell command for screen formats
- no calls to MOS utility programs
- no calls to some work station primitives

- to use the function keys, you must compare the VT100/VT200-like terminal key codes with the ones of the L1 MOS keyboard, then make the necessary mapping.

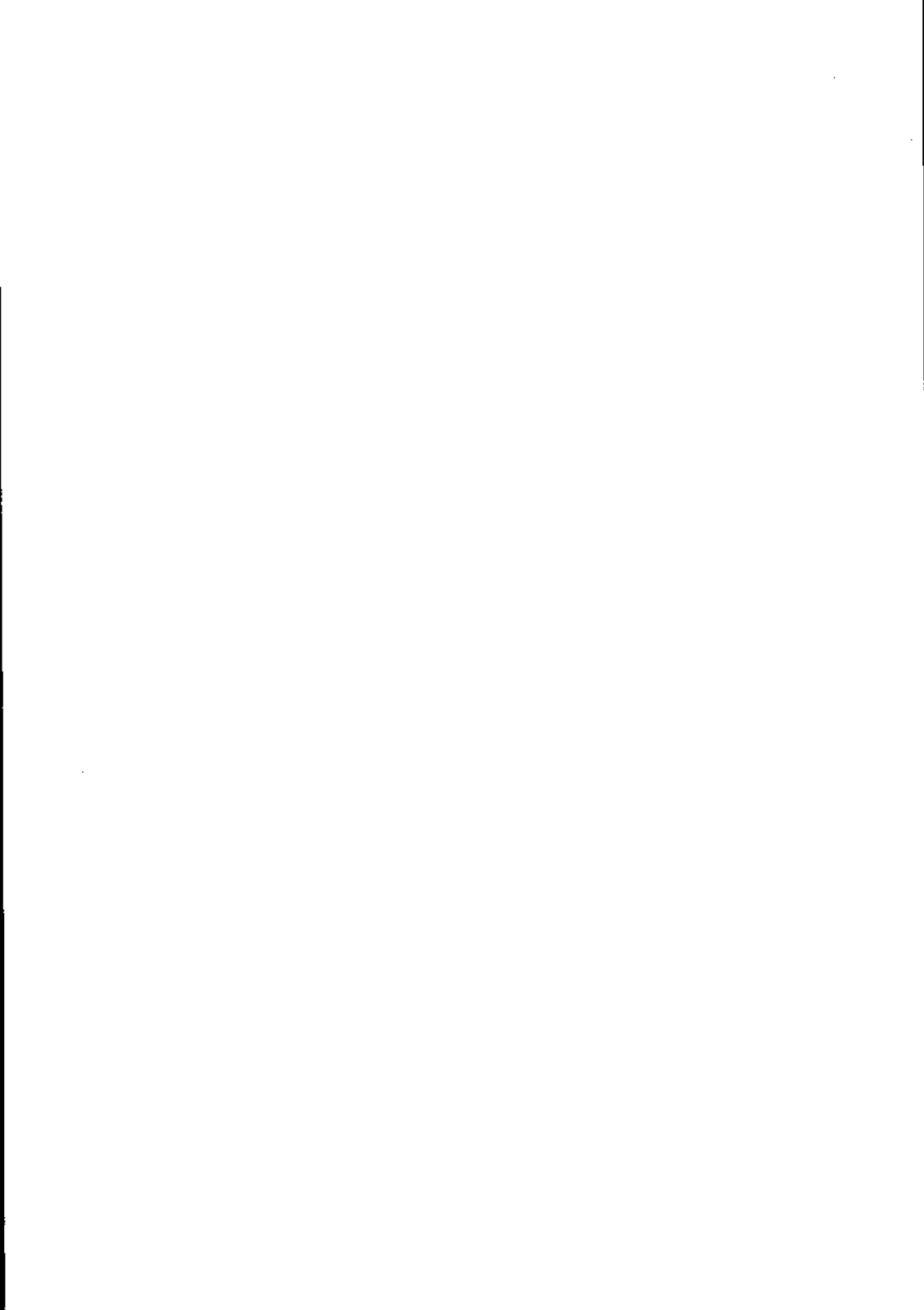

5. PRINTERS

ABOUT THIS CHAPTER

Chapter 5 indicates and describes all the printers connected to the system.

PRINTERS

A great variety of printers can be connected to L1 systems for document handling (continuous or discrete forms), quality and printed output.

All printers can be connected to the system's basic unit via RS232 C (V24) serial interface by using the CPU or MUX boards. Connection is made either directly or through the ELB 1382/3684 signal amplifiers.

Given the various printer models available, systems can be configured to meet a wide range of user application needs. The following types of printers are available:

General Purpose Printers: using dot matrix impact technology and suitable for various application sectors. They are:

DM 290, PR 19/B, PR 1580, DM 286, DM 296, DM 400, DM 600.

Letter Quality Printers: using interchangeable daisy wheel technology and suitable for word processing applications. They are:

DY 450, DY 800.

Specialized Printers: used in applications that require paper and document handling, typical of banking and service environments. They are:

PR 2845, PR 2850, PR 2880, PR 40/1, PR 40/2, PR 40/3, PR 40/4, PR 40/5.

Hard Copy Printers: used for printing out the content of the display screen and are typical work station printers. Olivetti offers the DM 280 as hard copy printer.

High Speed Printers: using continuous character band impact technology to produce high volume printer output. They are:

PR 3300, PR 3600.

The following figure illustrates the PR 3300 printer.



Fig. 5-1 PR 3300

NOTE: For additional information on the single printers, read the corresponding manuals found inside the printer pack. Should the manual be missing, ask the supplier to provide it for you.

6. MAGNETIC UNITS AND HOW TO USE THEM

ABOUT THIS CHAPTER

Chapter 6 describes the magnetic units connected to the system and indicates how to use them.

CONTENTS

DISKETTE UNIT	6-1	MOUNTING MAGNETIC TAPES	6-15
HOW TO USE AND HANDLE DISKETTES	6-4	CONTROL PANEL	6-16
HOW TO INSERT/REMOVE 5.25 INCH DISKETTES	6-6	TAPE REMOVAL	6-17
HOW TO INSERT/REMOVE 8 INCH DISKETTES	6-7	ERROR SIGNALS	6-18
HARD DISK UNITS	6-9		
HOW TO USE THE SWITCH DEVICE	6-10		
STREAMING TAPE UNIT	6-11		
HOW TO USE THE STREAMING TAPE UNIT	6-12		
HANDLING TAPE CARTRIDGES	6-12		
HOW TO INSERT/REMOVE STREAMING TAPE CARTRIDGES	6-13		
MAGNETIC TAPE UNIT	6-14		

MAGNETIC UNITS AND HOW TO USE THEM

There are various types of magnetic units in disk or tape format. The disk units are used as main data storage device and as backup device too, whereas the tape units are used as backup device only. The disk units used are the diskette and the hard disk and the tape units are the streaming tape and the magnetic tape reel.

DISKETTE UNIT

The diskette unit is available for all the L1 MOS line systems and uses the diskette as data storage magnetic device. There are three types of diskettes, that is:

- 5.25 inch, 320K byte diskette
- 5.25 inch, 1 Mbyte diskette
- 8 inch, 1 Mbyte diskette

The 5.25 inch 320K byte SLIM type diskette unit is housed in the basic unit and is available for the M54 system only. The 5.25 inch 1 Mbyte SLIM type diskette also housed in the basic unit, is available for all the systems of the line. The 8 inch diskette unit is housed in CAB 7019 cabinet and is available for M64/M70 systems. All units are provided with a led which lights every time the diskette is accessed. The 5.25 inch diskette units look all alike from the outside.

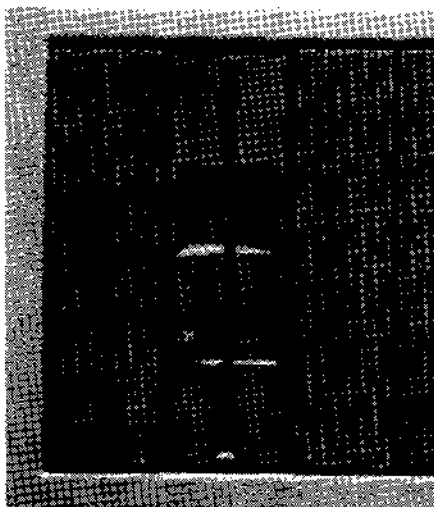

Fig. 6-1 5.25 inch Diskette Unit on M64/M70

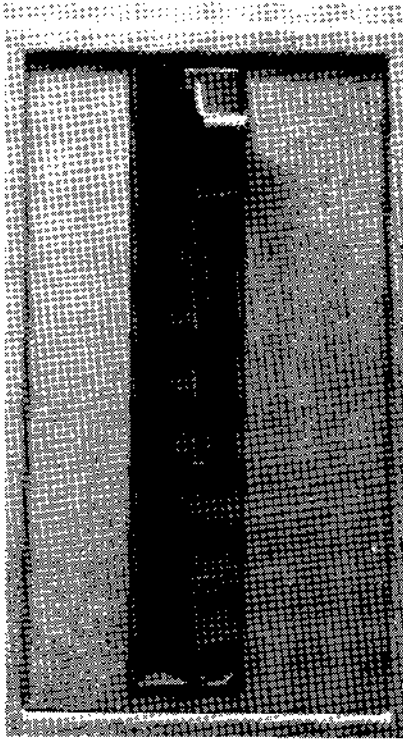

Fig. 6-2 8 inch Diskette Unit

The 5.25 inch diskette can be used either as main storage device, whenever the system does not have a hard disk, or as hard disk backup. But the 8 inch diskette can be used as backup only, to store data contained on hard disk.

HOW TO USE AND HANDLE DISKETTES

The illustration below shows a diskette and its protective envelope.

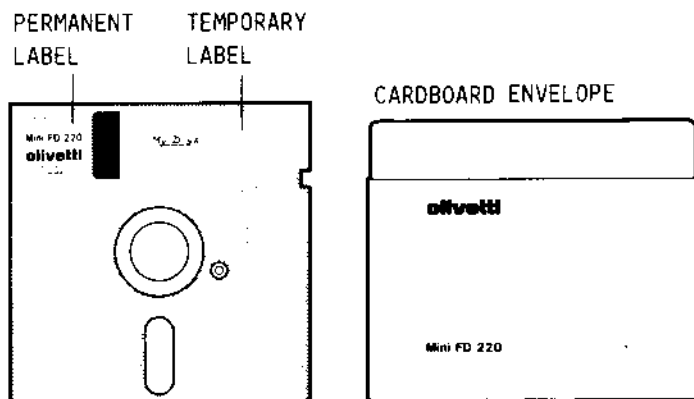

Fig. 6-3 5.25 inch Diskette

On the diskette there are two types of labels (see figure 6-3):

- Permanent label, provided by the manufacturing company
- Temporary label, placed on the diskette by the user.

The permanent label identifies the type of diskette, its code, and the manufacturing company. The temporary label contains information about the diskette and its contents.

When attaching a label on a diskette, you must be very careful not to damage the diskette physically. Thus it is important to follow some specific rules when placing a label, that is: avoid writing on the temporary label when already on the diskette. If the diskette content is changed, you should remove the old label instead of writing on it and attach a new one. If you write on an attached label with a pen, the point of the pen could ruin the diskette's magnetic surface.

Although diskettes are not particularly fragile, certain rules should be observed when handling them to avoid possible damages.

- Keep the diskettes away from magnetic fields and heat.
- Do not bend diskettes; even though they are flexible, if bended excessively their magnetic surface might get damaged.
- Do not touch the exposed surface of a diskette; when handling a diskette, hold it at the label end of its protective cover.
- Dust should not deposit on the diskette's magnetic surface; thus, when not in use, the diskettes should be inserted in their protective envelopes and stored in their cardboard box.
- If a diskette has been stored or kept in an environment other than its working environment, it should be left to acclimatize for about 5 minutes before using it.

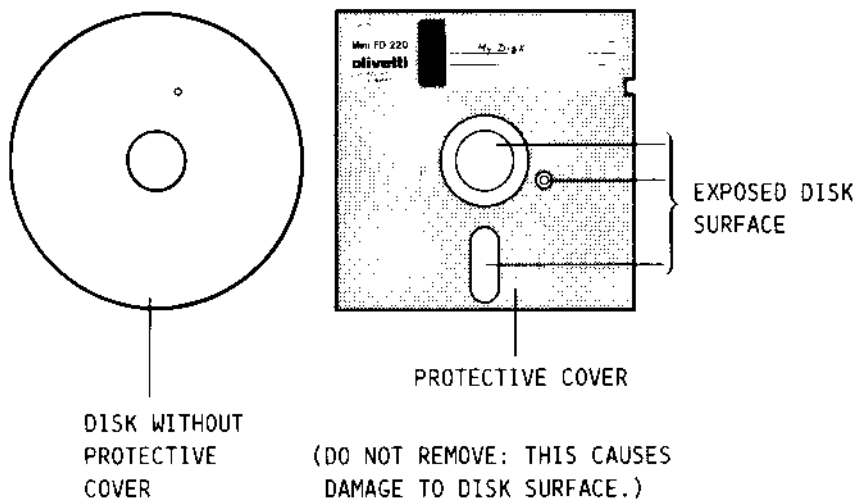

Fig. 6-4 Details of the 5.25 inch Diskette

Write Protection

Diskette information can be protected by using special metallized self-adhesive stickers. Place the sticker over the notch on the upper right side of the diskette next to the temporary label. In this way the diskette contents can be read but writing on it is not allowed.

Whenever you want to add new information and/or make modifications on a write-protected diskette, simply remove the sticker from the notch to enable writing.

The figure below shows how to write-protect a diskette: take one of the stickers supplied with the diskettes and attach it over the diskette notch.

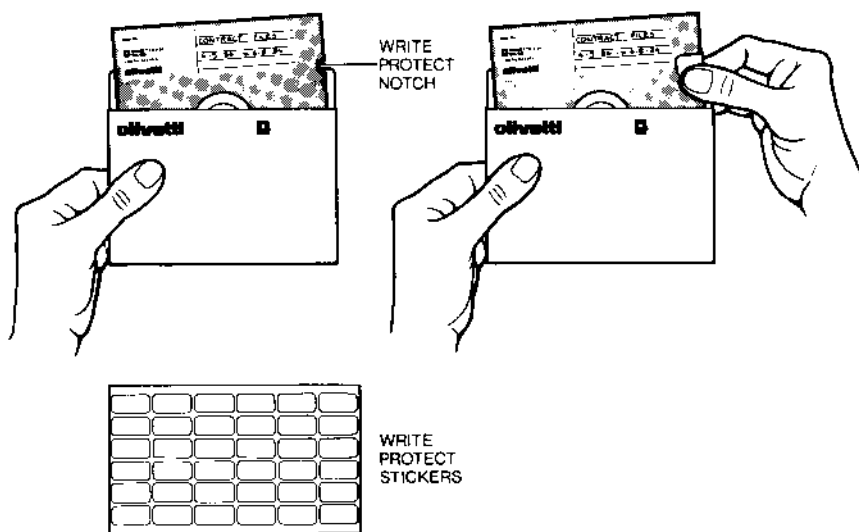

Fig. 6-5 Write Protection

HOW TO INSERT/REMOVE 5.25 INCH DISKETTES

The first thing to do when you want to insert a 5.25 inch diskette inside the unit drive is to open the drive cover using the appropriate lever. Then insert the diskette with its permanent label facing the lever on the warning light side. Push the diskette inside the drive until it clicks into place and close the drive cover by using the lever.

A diskette is normally used for I/O operations.

To remove the diskette, at the end of I/O operations, open the drive cover by using the appropriate lever and pull the diskette out with your hands. Then replace the diskette in its protective envelope. Remember never to remove a diskette while operations are being carried out on it.

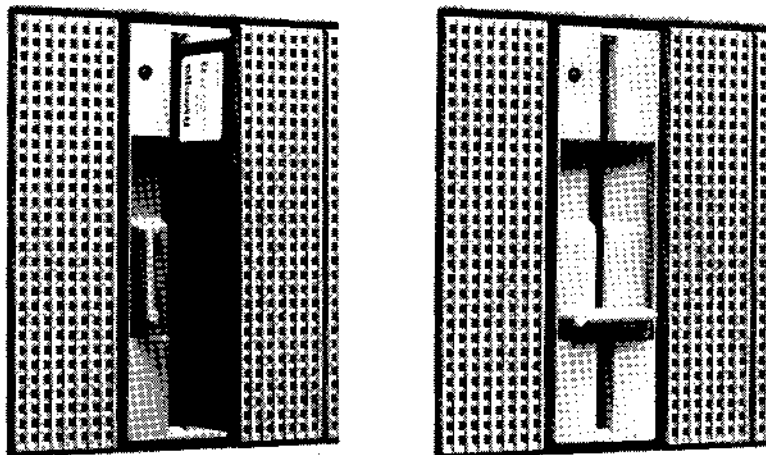

Fig. 6-6 Inserting a 5.25 inch Diskette on M64/M70

HOW TO INSERT/REMOVE 8 INCH DISKETTES

Take out the diskette from its protective envelope.

Insert the diskette in the drive and push it inside until it clicks into place. The label placed on the diskette must face the left.

Lower the drive lever once the diskette is correctly inserted inside the unit drive.

The operation of removing the diskette from the drive is very simple, that is, lift up the drive lever and the diskette is pushed out halfway automatically. You then pull out the diskette completely from the drive unit and place

it inside its protective envelope ready to be filed according to the rules previously described.

NOTE: Never remove a diskette while operations are being carried out on it.

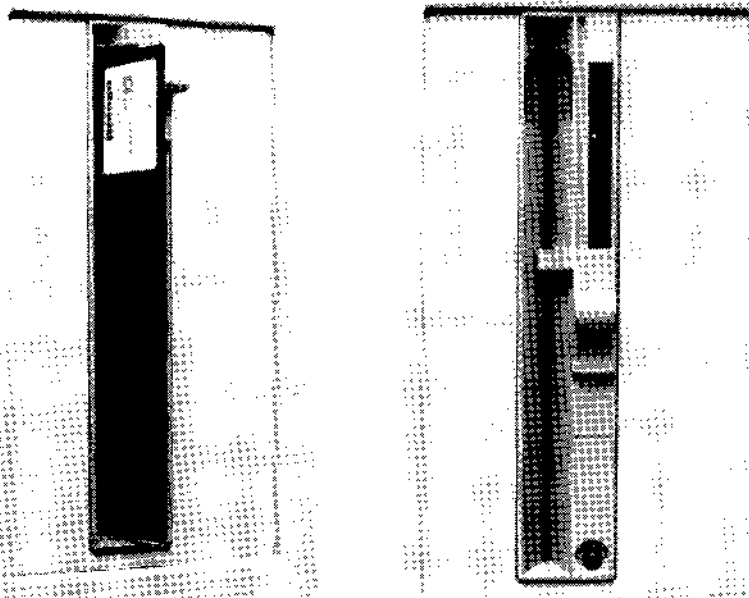

Fig. 6-7 Inserting the 8 inch Diskette

HARD DISK UNITS

All L1 MOS line systems can use the hard disk as their main data storage device. Compared with the diskette, the hard disk can store a greater quantity of data being its memory capacity much larger. The various memory capacities of hard disks are:

- 20 Mbytes
- 40 Mbytes
- 65 Mbytes
- 140 Mbytes
- 60 Mbytes
- 120 Mbytes
- 275 Mbytes

The 20/40/65/140 Mbyte hard disks are housed in the basic unit of the M54/M64/M70 systems, whereas the 60/120/275 Mbyte hard disks are incorporated in the CAB 7018 cabinet and can be shared by two different systems provided they are supplied with the DUAL PORT option.

All the systems supplied with hard disks have their basic and application software stored on the hard disks. The removable device are used only for backing-up the contents of the hard disks. The hard disk backup units available are:

- 5.25 inch diskette unit
- 8 inch diskette unit
- streaming tape unit
- magnetic tape unit

The reason for backups of disk content is to dispose of the content of the hard disk in the event the hard disk gets accidentally damaged.

From an operation point of view, hard disks do not need any particular user intervention, except for when shared, as they must be manually selected for the system to which they are assigned. For this purpose these hard disk units are provided, besides the normal console, with a special switch device consisting of a key lock and four leds.

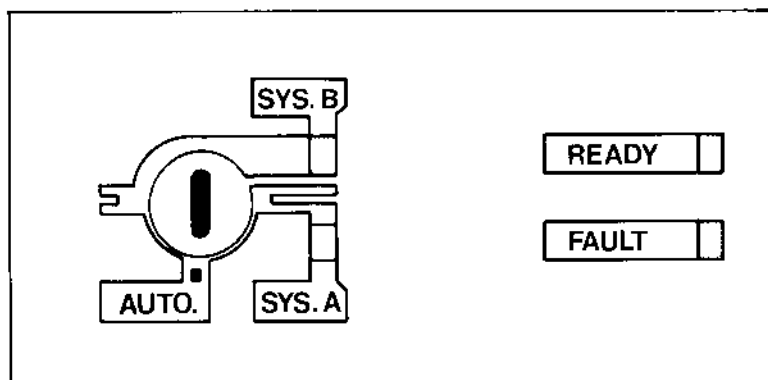

Fig. 6-8 Console with Special Switch Device

The console and the Switch Device illustrated in the figure above, show the following information:

- **FAULT:** this red-colour LED, lights to indicate an incorrect unit condition.
- **READY:** this green-colour LED, lights to indicate that the unit is correct and is ready to be used.
- Key positioned on "A": the unit is assigned to system "A"
- Key positioned on "B": the unit is assigned to system "B".

The yellow LEDs situated on "SYS A" and "SYS B" positions, light to indicate which system is using the unit (obviously this indication is visible only to the system previously assigned to this resource).

HOW TO USE THE SWITCH DEVICE

The "DUAL-PORT" switch device, used when two systems share the same hard disk, can be operated manually.

Only one system at a time can access the hard disk. To enable a system

to use the hard disk simply turn the switch device key on "SYS A" or on "SYS B". What happens then is:

- The system enabled to use the hard disk, can carry out operations on the unit.
- Now, if the other system asks to access the hard disk, it receives a code in reply indicating that the hard disk is not available.
- It is not possible to turn the switch from one system to the other while I/O operations are being carried out on the hard disk.

Hard disk switching between systems is usually required in cluster environments with backup satellites when the Master is down. In these circumstances, the Master must first be powered-off before making the switch.

STREAMING TAPE UNIT

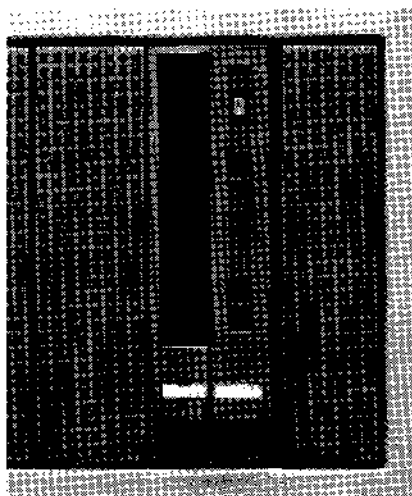

Fig. 6-9 Streaming Tape Unit on M64/M70

The 5.25 inch streaming tape unit is available for all L1 MOS systems and is used as hard disk backup. It has a capacity of 45/60 Mbytes, and can be housed comfortably inside the basic unit.

HOW TO USE THE STREAMING TAPE UNIT

To use the unit correctly, you should operate as follows:

- Data is transferred only with dedicated system.
- The tape content should be cancelled before making any attempt to record on it (you cannot record in areas that are already recorded).
- With frequent use of new tapes, it is necessary to clean the print head every 15 recorded cartridges.
- When using the tape normally, the print head should be cleaned every eight hours of tape run (corresponding to about 50 dump operations).
- When using the system not very often, clean the print head every 24 hours of power-on as dust might deposit on the head when not in use.

HANDLING TAPE CARTRIDGES

To protect cartridges from damages or loss of data, you should operate as follows:

- When a cartridge is used for the first time (new cartridge) or in case of doubts, you must erase it completely.
- Remove cartridges before system power-on/power-off.
- The cartridge must always be positioned on BOT (beginning of tape) before operating on it.
- Store cartridges in a tape library in their appropriate containers and remove them from there only when they are to be used.
- Place the cartridges in the tape library vertically. Do not store them horizontally, nor store them one on top of the other.
- Do not expose cartridges for long periods to the direct rays of the sun and heat sources.
- Do not shake cartridges or subject them to shocks or blows of any kind.
- If stored somewhere other than the working environment, cartridges should be allowed to acclimatize for a few hours before being used.

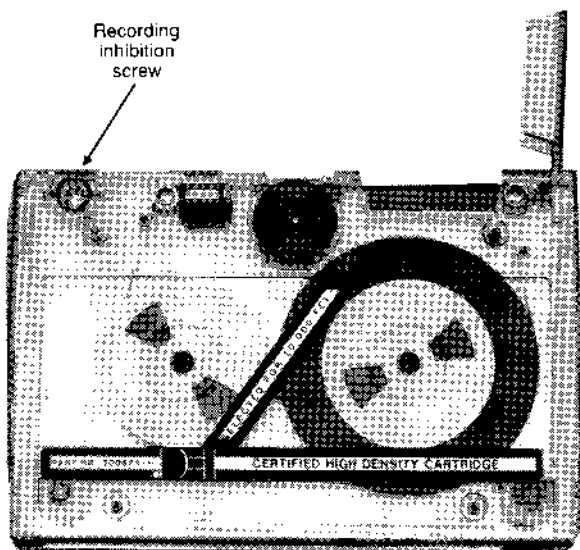

Fig. 6-10 Streaming Tape Cartridge

Figure 6-10 illustrates the streaming tape cartridge. As can be seen from the illustration given, the cartridge has a recording inhibition area. Recording is inhibited by turning the screw marked with "SAFE". On the cartridge there is a slot which opens automatically when the cartridge is inserted inside the unit to allow the read/write head to come into contact with the tape.

HOW TO INSERT/REMOVE STREAMING TAPE CARTRIDGES

Cartridges must be inserted inside the front access slot of the unit. When inside the slot, cartridges must be pushed in until they click into place and must be blocked with the appropriate lever lifted up (M64/M70) or pushed to the right (M54).

Cartridges are removed by unblocking them from inside. First push the lever down (M64/M70) or to the left (M54), then remove them from the drive.

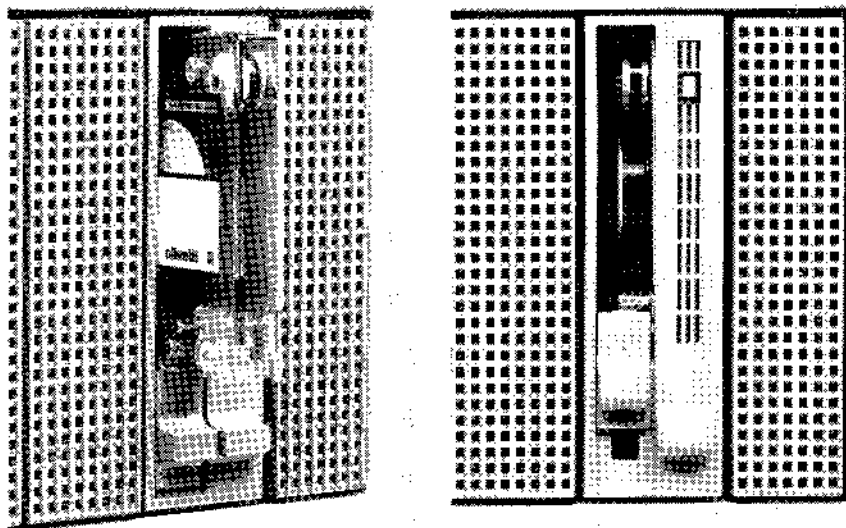

Fig. 6-11 Insertion of Tape on M64/M70

MAGNETIC TAPE UNIT

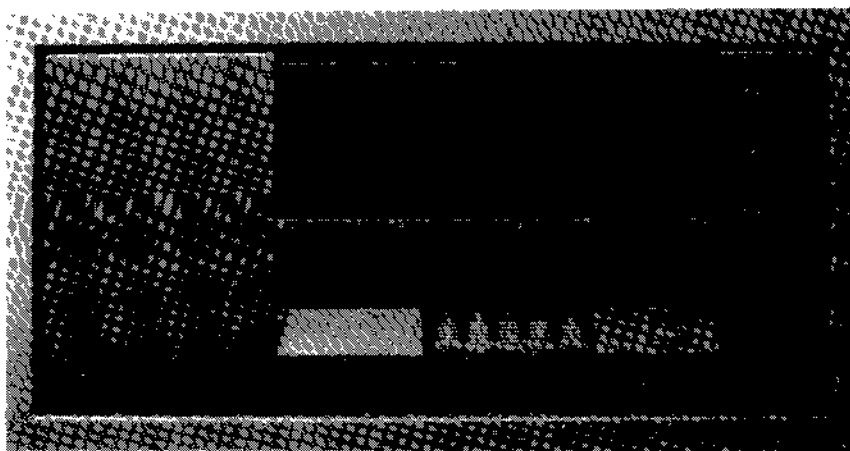

Fig. 6-12 Magnetic Tape Unit

The magnetic tape unit is the backup device generally used for storing large quantities of data or transferring data in big amounts to another system. The magnetic tape unit is available for M64/M70 systems and is housed in CAB 7018.

The unit uses tapes of 1/2 inch, 1600 bpi, ANSI standard recording, IBM compatible. It operates in streaming mode at high speed (100 ips) and low speed (25 ips) in Start/Stop operations. The tape is contained in reels with 40 Mbyte capacity.

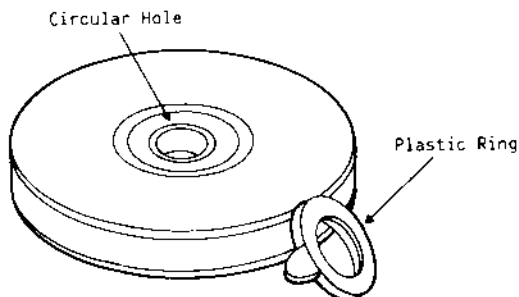

Fig. 6-13 Magnetic Tape Reel

On the rear side of the reel containing the tape, there is a "write protect groove" for the insertion of a plastic ring. If the ring is inserted, the tape can be read and written. If the ring is removed, the tape can be read only.

MOUNTING MAGNETIC TAPES

Before describing how to mount magnetic tapes on unit, we indicate hereafter how magnetic tape reels should be handled:

- Use magnetic tape reels only when needed, that is, for storing data or providing data to the system.
- When holding a reel in your hands, do not press its borders.
- The only part of the tape that can be touched with the hands is its initial part.

- Should anything occur that might compromise tape integrity, the preceding rule may be ignored. In fact if you are in need to rewind the tape, take hold of it only with your fingertips on its borders.
- Avoid operations or situations that could compromise tape integrity.

To mount the tape on the unit is a very simple operation carried out with a bit of attention. That is:

- Power-on the unit (switch at the right of the control panel).
- Open the reel access slot.
- Insert the tape reel into the unit (the transparent part facing up).
- Close the reel access slot.

CONTROL PANEL

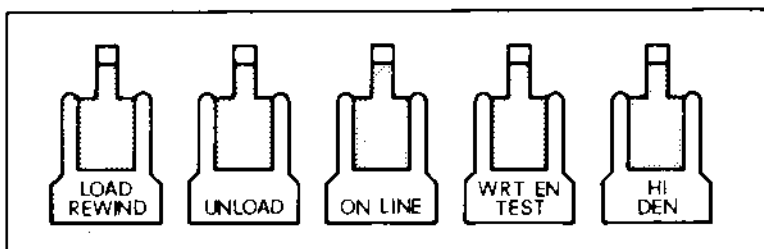

Fig. 6-14 Control Panel

The control panel is located in the central part of the Unit. The keys on the control panel permit checking and controlling of tape operations. Each key on the control panel is associated to a LED indicating the operational state of the unit and possible error conditions.

LOAD/REWIND Key

After mounting the tape on the unit, you can press this key to advance the tape to BOT (Beginning of Tape) position when loading or rewinding tape. The "LOAD/REWIND" led flashes while the comand is being performed and stops flashing but remains lighted when the tape is at BOT position.

UNLOAD Key

By pressing this key you preset the conditions for tape removal. The "UNLOAD" led flashes while the comand is being performed but stops flashing and remains lighted when the tape is ready to be removed. With the "UNLOAD" led lighted you can now open the reel access slot and remove the tape.

ON-LINE Key

Pressing this key places the magnetic tape unit under system control. With the ON-LINE led lighted, the system interface is active and all the other keys on the control panel are disabled.

NOTE: The ON-LINE key is a bistable key; if pressed while tape writing is being performed, it causes writing abort and change into OFF-LINE state.

WRTEN/TEST Key

The WRTEN/TEST key is a bistable key. If pressed once, this attributes test functions to the other control panel keys (LOAD/REWIND, UNLOAD, ON-LINE). The WRTEN/TEST led remains lighted. Test codes must be entered within one second. Pressing this key a second time, restores the control panel keys to their original functions. When the WRTEN/TEST led remains lighed in normal operating conditions, it indicates that the tape is enabled for writing.

NOTE: Remember that tape writing can be disabled by removing the plastic "write-enable" ring inserted in the reel's write protection groove.

HI/DEN Key

This key and corresponding led are used only for diagnostic tests.

TAPE REMOVAL

Tape removal is very simple. Activate the "UNLOAD" key. This causes tape rewinding and release of the hooks blocking the tape reel in the unit. Now you can remove the tape reel and store it in its protective case.

ERROR SIGNALS

The control panel LEDs can assume different configurations, each representing a specific error signal. The errors signalled indicate either recoverable errors, the ones that you can easily correct yourself (see table A), or unit malfunctions which require the intervention of a Field Engineering technician (see table).

T A B L E "A"					RECOVERABLE ERRORS
LOAD REWIND	UNLOAD	ON-LINE	WR TEN TEST	HI/DEN	MEANING
X	X	X	X	X	4 unsuccessful attempts have been made to load the tape. Check the beginning of tape.
	X	X	X	X	No BOT marker found in first 35 feet of tape.
X		X	X	X	Tape reel inserted upside down. (Write protect ring at the bottom).
X	X		X	X	Attempt to make a LOAD with front slot open.
X	X	X		X	Attempt to make a LOAD with no tape reel inserted.

T A B L E "B"

NON-RECOVERABLE ERRORS

LOAD REWIND	UNLOAD	ON-LINE	WRTEN TEST	HI/DEN	MEANING
X	X				More than 3700 feet of tape found after BOT.
			X		Tape too tight during loading.
X			X		MTU command received before previous command completed.
	X		X		Write command used on a "write-protected" tape.
X	X		X		Transmission of illegal command.
				X	The drive wheel cannot hook the tape during loading.
	X			X	At Power Up time the analog digital convert has signalled an error during diagnostics.

T A B L E "B"

NON-RECOVERABLE ERRORS

LOAD REWIND	UNLOAD	ON-LINE	WRTEN TEST	HI/DEN	MEANING
		X	X		Tape reel positioned incorrectly or tape is write protected.
X		X	X		Tape reel blocked during UNLOAD.
	X	X	X		Tape past EOT mark by 18 feet.
X				X	Tape is too loose in normal operating conditions.
	X			X	Tape speed exceeds tolerance level.

7. HOW SYSTEM OPERATES

ABOUT THIS CHAPTER

Chapter 7 describes the steps to be performed by the system or by the system manager before connecting work stations. It also describes how to connect/disconnect work stations to/from the system. The last paragraph indicates how the system manager can deactivate the system.

CONTENTS

ACTIVATING THE SYSTEM	7-1
AUTODIAGNOSTICS	7-1
LOADING OF OPERATING SYSTEM	7-2
BACKUP SATELLITE	7-2
SYSTEM INITIALIZATION	7-3
MASTER TERMINAL	7-4
ERROR MESSAGES	7-5
CONNECTING/DISCONNECTING USERS	7-6
LOGIN	7-6
LOGOUT	7-8
MASTER WORK STATION (MWS)	7-8
SYSTEM DEACTIVATION	7-8
SHUTDOWN OPERATIONS	7-10

HOW SYSTEM OPERATES

ACTIVATING THE SYSTEM

The system is activated by carrying out the following operations in the order given:

- Power-on the system by inserting the plug in the power socket.
- Turn the main power switch to ON.
- Using the console (ISL function) indicate from which device the operating system is loaded (see chapter 3). The MOS operating system is loaded either immediately after autodiagnosics (by default), or by selection from menu.
- If the system is not configured with the hard disk, mount the magnetic device containing the operating system to be loaded in Main Memory (see chapter 6). For additional information see the manual: "System Software Generation and Installation - code 4002160 B" and read the chapter on "Installation Process".
- If the system is using an extended console, turn the key in position "RUN" (see chapter 3).

AUTODIAGNOSTICS

When the system is activated, it enters the autodiagnostic phase, which performs certain tests to check the system hardware operating conditions.

When the autodiagnostic tests detect a malfunction, the system displays a diagnostic message on the console display.

By comparing the message with a given autodiagnostic list, you can immediately know what is the cause and the hardware component concerned with the malfunction.

But, if there are no anomalies, the system enters the next phase, which is the IPL (Initial Program Loading) phase.

LOADING OF OPERATING SYSTEM

IPL, which is the phase where the MOS Operating System is loaded into Main Memory from a designated unit (hard disk, tape, diskette), is carried out automatically as soon as all the autodiagnostic tests have been completed with positive results.

IPL is usually performed with the hard disk, if present. But, sometimes it is supported by a removable device (mFDU, FDU, STC, MTU).

Using the system console, you can select the type of device used for operating system loading.

If the system is configured with several numbers of units of the same type, and you select to load the operating system from one of them, it is the system's job to find which unit contains the operating system.

When the Operating System is loaded from Streaming Tape, it is first dumped from Streaming Tape to Hard Disk, from where it is then activated. This is a very delicate phase as there is the risk of losing user files. Therefore to avoid all this, you should save the files before doing anything else with them.

If IPL phase is not successful, for example, nothing appears on the display screen, then check that IPL has been performed with the correct device. Try it again, making sure to use the correct device. But if you still have troubles with IPL call the Field Engineering technician. Appendix B gives a list of all the errors and anomalies (warning) that you may possibly find during IPL.

BACKUP SATELLITE

A backup Satellite is used in cluster configurations to ensure normal operating conditions when the Master is down.

A backup Satellite is an M64 or M70 system normally operating as satellite system but, when required, capable of carrying out Master functions even though with some restrictions.

When the Master is not operating properly (e.g. power down), all the satellites are informed of the present situation and they can either continue to work locally and/or wait for resumption of Master operating conditions.

To be able to load the Master software onto the backup Satellite, the Satellite must be configured with a RAM memory greater than the one contained on a normal satellite. Besides this, the hard disk containing this software must be the type that can be shared between Master and backup Satellite.

Activating the Backup Satellite

To activate the backup Satellite as Master, it is necessary to use the system console and the switch device of the hard disk unit containing the Master software.

What you must do is:

- Using the console, select to load the operating system from hard disk. (See chapter 3).
- Turn the DUAL-PORT switch device, allocated on the hard disk shared between the Master and the backup Satellite, to the backup satellite position (see chapter 6).
- RESET the system (see chapter 3).

The backup Satellite will perform autodiagnosics and IPL, then it will load the Master software.

Once activated as Master, the backup Satellite informs all the other satellites of resumption of Master operating conditions in order to continue with the interrupted activities. This is possible because the Master software is comprised of recovery/restart capabilities, which protect all the files it contains from being damaged by Master down conditions.

SYSTEM INITIALIZATION

As soon as the IPL phase terminates correctly, system initialization begins.

System initialization is handled by a process called GRANDPA and may require operator intervention.

According to the information contained in its configuration file, GRANDPA prepares the various environments for the single work stations, defines a terminal as Master and activates the login program.

GRANDPA also activates background environments that can be used by various users during their activities on the system (spooler, batch job monitor, etc.).

NOTE: All the information contained in the configuration file can be modified interactively (using, for example, the editor), compiled using a specific shell command (PARSER) and become effective the next time the system is initialized.

MASTER TERMINAL

The Master terminal is a terminal reserved to the system manager where the IPL warnings are displayed. If requested by the configuration file, the Master terminal can also be used for carrying out some initial operations.

It is possible to define one, or more than one, Master terminal, or none at all, in the configuration file. If no terminal is defined, GRANDPA assumes one by default. If more than one have been defined, then only one is accepted as Master while the others are used only when the declared Master is down.

If requested in the configuration file, after display of the IPL warnings or if software and hardware configurations match, on the Master terminal there appears a message requesting to enter the date and the time of start of activity, and/or to change the system volume.

Enter Date and/or Time of Start of Activity

The date is to be entered in the form: MM/DD/YY (Month/Day/Year); the time in the form: HH/MM/SS (Hour/Minutes/Seconds).

If you do not enter the date and the time correctly, GRANDPA asks you to re-enter them in the correct form.

NOTE: A specific SHELL command (SETDATE) is available for checking and entering the date and time desired.

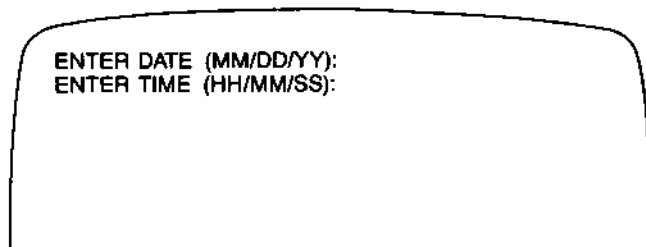

Fig. 7-1 Entering Date and Time

Changing System Volume

To change the system volume you must give GRANDPA the name of the directory in full, which will be the identifier of the new logical volume.

If the device used for IPL is the diskette, you must change the diskette physically and press the **CR** key to confirm the system of the change of diskette.



Fig. 7-2 Changing System Volume

NOTE: When, during preliminary Master interaction, a work station blocks, or is switched off accidentally before having terminated the various initialization procedures, all the operations can be executed again on another terminal.

ERROR MESSAGES

If a system is not initialized correctly, a message appears on the Master terminal indicating why the initialization procedure aborted. Various messages can be displayed, these are:

GPA CAN'T ACCESS \$CONFGP

displayed when GRANDPA cannot find or access its configuration file.

ERROR IN MOUNTING DISK

displayed when there are problems in changing the system volume.

WARNING : GPA UNABLE TO CALL/START <NAME>

displayed when GRANDPA is not able to activate environment or program indicated. NAME is the name of the environment/program that GRANDPA has not been able to activate.

CONNECTING/DISCONNECTING USERS

As soon as the system has been initialized, the work stations are ready for user applications. The work stations connected to the basic unit via KDC controller are available immediately, whereas the others must be activated using the specific switch.

A user can connect himself to the system only after having activated his work station.

If there is a "data base login" during initialization, GRANDPA activates the login program and the various users of the connected work stations must give their identifications in order to be connected to the system.

NOTE: Even if there is the "data base login" feature, it is possible to skip the login phase for some work stations, provided it is established so at configuration time.

LOGIN

Login is the phase where you enter your identification on the keyboard which permits you to have access to the system. Several other users may have access to the system using the same work station, provided their identifications are contained in the "data base login" and that the work station has not been associated, during configuration, to some specific users only.

An identification is usually made up of two words, one is the name of the user, the other is his password. Therefore a login is performed in two distinctive steps: in the first step you are asked to enter your name; in the second step, your password. Both entries of name and password must be confirmed by pressing the **CR** key; password entries are transparent, this means that whatever you enter as password does not appear on display screen for safety reasons.

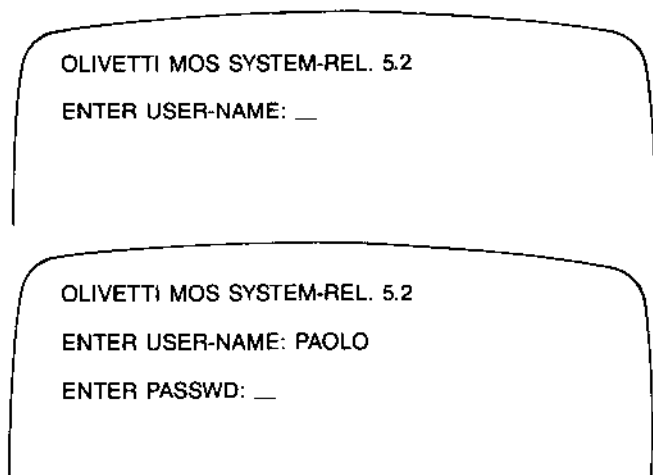

Fig. 7-3 The Two Login Steps

The login program compares the identification you entered with the ones contained in the "data base login" and, if found, you are connected to the system and you are ready to start your activities.

If the system does not find the identification you entered, it requests the login again and the entire procedure must be repeated.

On the other hand, if the system finds it, a menu is displayed on the screen indicating all the environments available for that work station.

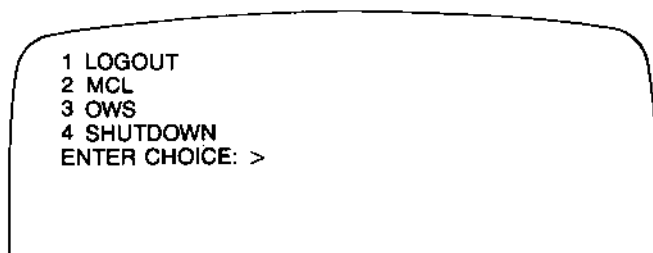

Fig. 7-4 Menu Example

You can select the environment desired from the menu given, by entering the number associated to the selected environment, then **CR**. The environment selected is activated by GRANDPA. The activated environment is available when the prompt appears on the screen (the prompt of the SHELL environment is MCL:). If the selected environment cannot be activated, an error message is displayed.

When a work station is configured for a single environment only, GRANDPA activates it without waiting for your selection.

LOGOUT

You can exit from the environment which you were working with as soon as you have completed your activities.

To logout from the SHELL environment, enter LOGOUT and press **CR**.

The menu reappears on the display after logging out from an environment. At this point you can select a new environment or disconnect yourself from the system. You log out by entering 1 in response to the displayed menu (see Fig. 7-4).

MASTER WORK STATION (MWS)

The Master Work Station is a virtual terminal used by the system manager to receive messages from the various users of the work stations.

It consists of the status line of the terminal assumed as Master for initial operations, which is the Warning terminal of MWS, and of 24 lines of the terminal assumed as Master of MWS, which need not be the Warning terminal but a different one.

When you send a message to MWS using a specific Shell command, an indication appears on the Warning terminal and the message is read on the terminal enabled for this scope by GRANDPA, which then becomes the Master terminal of the Master Work Station.

SYSTEM DEACTIVATION

To close all activities, the system manager uses the SHUTDOWN command (function 4 in Fig. 7-4).

The system displays the next screen and asks how many minutes should pass before starting the system SHUTDOWN. The default value is 90 seconds. For the default value simply press **CR**. For a different time,

reply to the system by entering the number of seconds desired followed by **CR** .

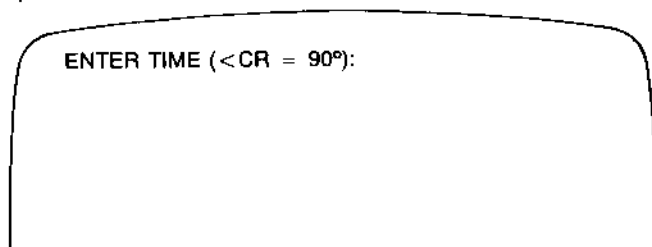

Fig. 7-5

The system manager communicates his intention of shutting down the system by sending a specific message on the screen of **all** the work stations connected. When the users receive this message they must close their working session and disconnect their work station from the system in the lapse of time indicated by the system manager.

The end of system SHUTDOWN is communicated on the screen from which it was activated with the following message:

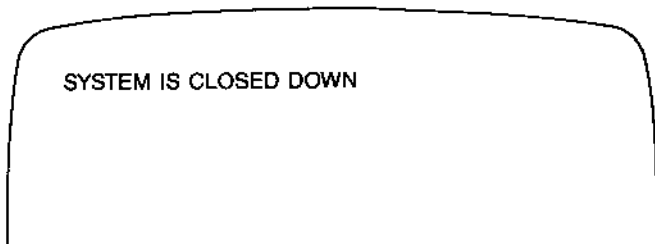

Fig. 7-6

At this point the system and all its peripherals must be powered off.

SHUTDOWN OPERATIONS

To physically shutdown the system carry out the following steps in the order given:

- Remove the devices from the various magnetic units as described in chapter six.
- If the system is configured with an extended console, turn the key to STAND-BY position (see chapter 3).
- Place the main switch OFF.
- Power-off the various peripheral units.

8. HOW TO USE THE KEYBOARD

ABOUT THIS CHAPTER

Chapter 8 describes the functions of the keyboards configured in L1 MOS.

CONTENTS

KEY SIGNIFICANCE	8-2
SHIFT key	8-2
CONTROL key	8-2
ESC Key	8-3
REPEAT, BACK SPACE, CARRIAGE RETURN, TAB Functions	8-4
CHANGE WINDOW and HARD COPY Functions	8-5
ENTER and SKIP Keys	8-5
Cursor Movement Keys	8-6
IL/IC, DL/DC Keys	8-7
EXIT, HALT PGM Keys	8-8
CLEAR/ERROR Key	8-9
CL.ER Key	8-10
CLEAR Key	8-10
ERASE/SEND Key	8-11
Function Keys	8-12

HOW TO USE THE KEYBOARD

On the keyboard there are 5 leds to inform you of the functional and operating conditions of the work station.

Four leds are located on the keyboard in the upper right side, the other led is on the extreme left side.

The meaning of the 4 right leds are:

- **POWER ON:** indicates that the keyboard is activated.
- **READY** {
 off: the system cannot receive input data.
 on: autodiagnosics terminated;
 the system can receive input data from the keyboard.
- **L1:** the indications given by this led are for special application programs only.
- **L2:** during Editor it indicates, if on, the INSERT state; during program run time it indicates that the system is waiting for a keyboard input.

The led on the left is associated to the **SHIFT LOCK** key (business and multifunctional keyboards), or to the **KB MODE** key (scientific keyboard). This led has the following meaning:

- **off:** {
 indicates keyboard NORMAL state; that is, only the alphanumeric characters on the lower part of the keys (first level) are accepted.
- **on:** {
 indicates keyboard SHIFT LOCK state; that is, only the alphanumeric characters on the upper part of the keys (second level) are accepted.

KEY SIGNIFICANCE

Below is given the meaning of the keys in the keyboard layout illustrated in chapter 4. The numeric and function keys can be customized according to user requirements.

SHIFT key

This key generates the second alphanumeric keys level and, in scientific keyboards, the second function keys level as well.

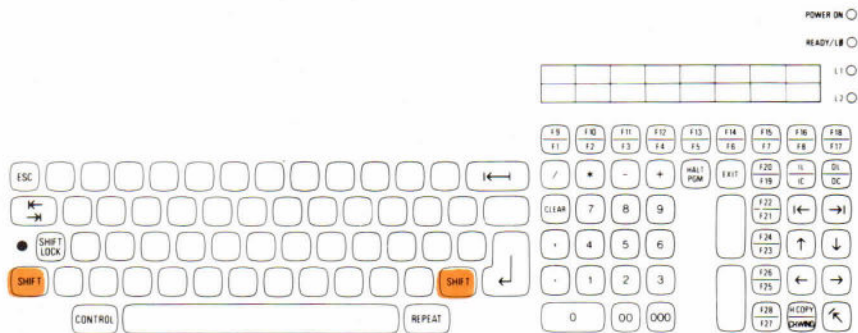

Fig. 8-1 SHIFT Key

CONTROL key

For business and multifunctional keyboards, if associated with a key of the function area it generates the second level (upper part) of that key. But in scientific and multifunctional keyboards, if associated with a key of the alphabetical area it generates the ISO code relevant to that key.

Default functions are assigned to the **CONTROL K** , **CONTROL S** , **CONTROL Q** keys:

- **CONTROL K** : kills the process in execution
- **CONTROL S** : stops scrolling on display screen
- **CONTROL Q** : resumes scrolling on display screen

It is possible to change, via application program, the default function of **CONTROL K** , and assign new functions with the combination of **CONTROL ALPHABETICAL KEY** .

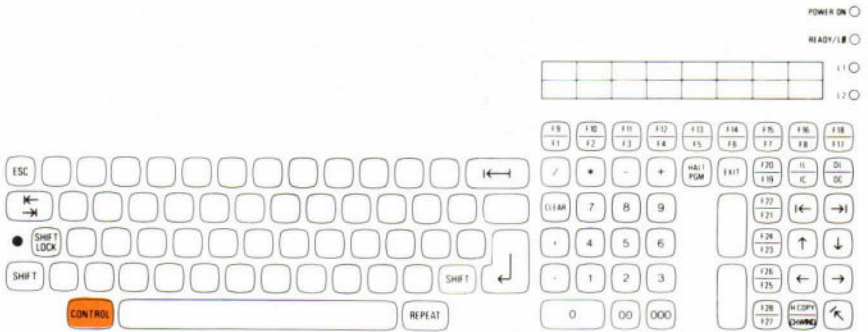

Fig. 8-2 **CONTROL** Key

ESC Key

This key is available only on multifunctional keyboards. When associated to another key of the alphanumeric area it generates the ESC code independent of key level status.

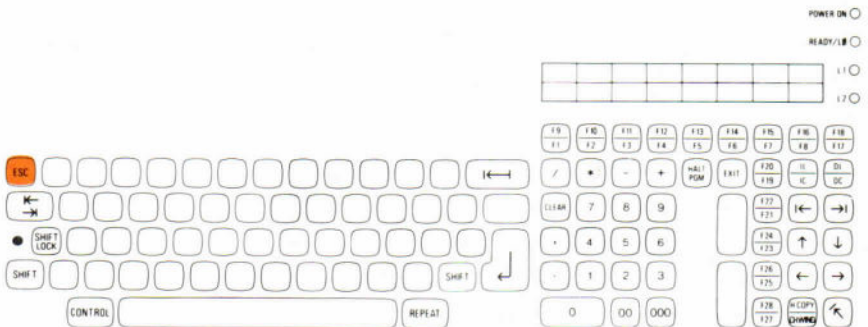

Fig. 8-3 **ESC** Key

REPEAT, BACK SPACE, CARRIAGE RETURN, TAB Functions

REPEAT Repeats the last character entered in autorepeat mode. This function is obtained by pressing the **REPEAT** key together with the key to be repeated, then by keeping only the **REPEAT** key pressed the character involved is repeated.

BACK SPACE Deletes the character to the left of the cursor. This function is carried out by pressing the ← key and by keeping it pressed it continues in "autorepeat" mode.

CARRIAGE RETURN Moves the cursor to the beginning of the next line and closes keyboard entries. This function is carried out by pressing the ↵ key.

TAB Moves the cursor a number of positions to the right/left. In business and scientific keyboards, when the **TAB** key is pressed, the cursor moves to the right. In multifunctional keyboards there are two TAB levels: the first level (→|), obtained in NORMAL state moves the cursor to the right; the second level (|←), obtained in CONTROL state, moves the cursor to the left.

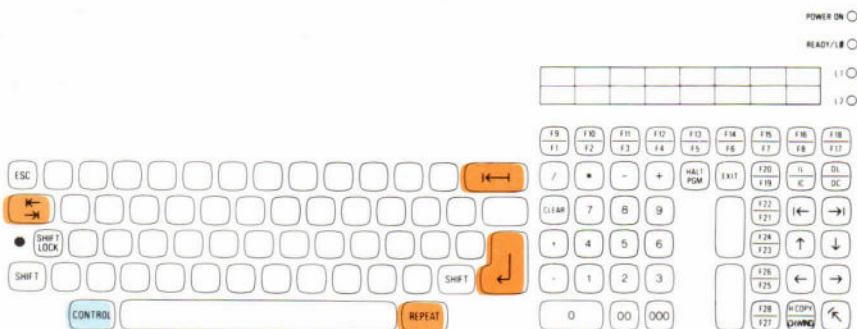

Fig. 8-4 REPEAT, BS, CR, TAB Functions in Multifunctional Keyboard

CHANGE WINDOW and HARD COPY Functions

The CHANGE WINDOW function is used for changing from one screen window to another. The function is carried out by pressing the **H.COPY/CH.WIND** key.

The HARD COPY function is used for printing the content of the current window on the hard copy printer. This function is carried out by pressing the following keys: **CONTROL** with **H.COPY/CH.WIND** (business and multifunctional keyboards) or **SHIFT** with **H.COPY/CH.WIND** (scientific keyboard).

NOTE: The functions of the **H.COPY/CH.WIND** key can be re-assigned by program.

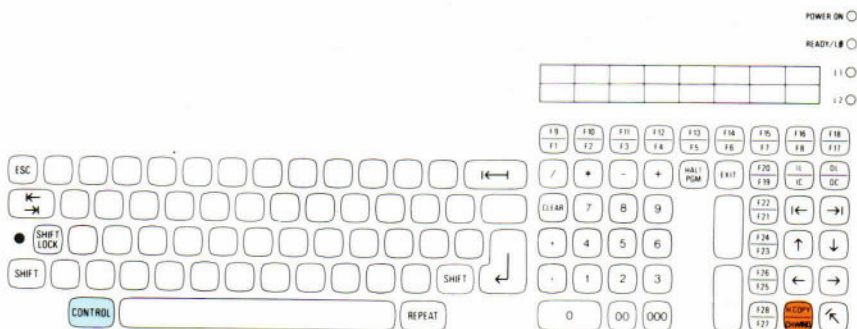

Fig. 8-5 CW and HC Functions in Multifunctional Keyboard

ENTER and SKIP Keys

The significance of these keys may change according to the environment in which they are used. Generally the **ENTER** key functions as a Carriage Return, whereas the **SKIP** key validates a variable.

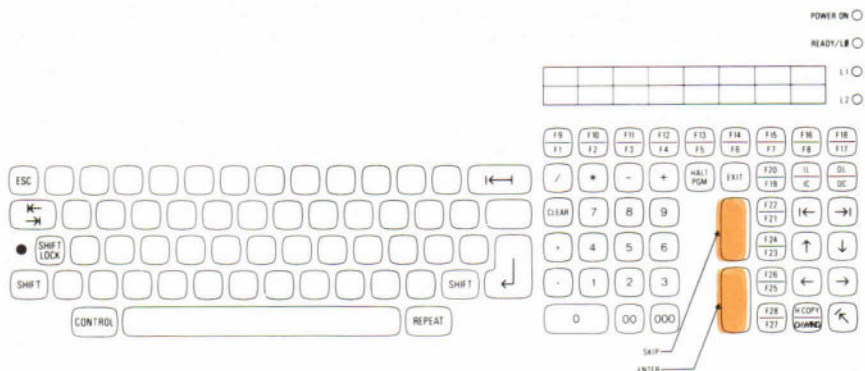

Fig. 8-6 ENTER , SKIP Keys

Cursor Movement Keys

The cursor movement keys are:

SYMBOL	DESCRIPTION
↶	HOME. Moves the cursor to the first position of the current window (upper left).
← → ↑ ↓	Moves the cursor one position to the left/right or one line up/down; it can be performed in autorepeat mode.
← →	Moves the cursor at the beginning/end of field.

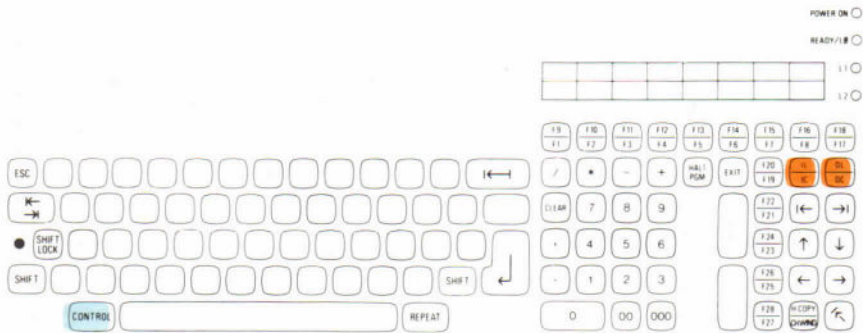

Fig. 8-8 IL/IC , DL/DC Keys in Multifunctional Keyboard

EXIT, HALT PGM Keys

The functions of these keys depend on the environment in which they are used: consult the specific environment manual. The **HALT PGM** is available on the multifunctional keyboard only.

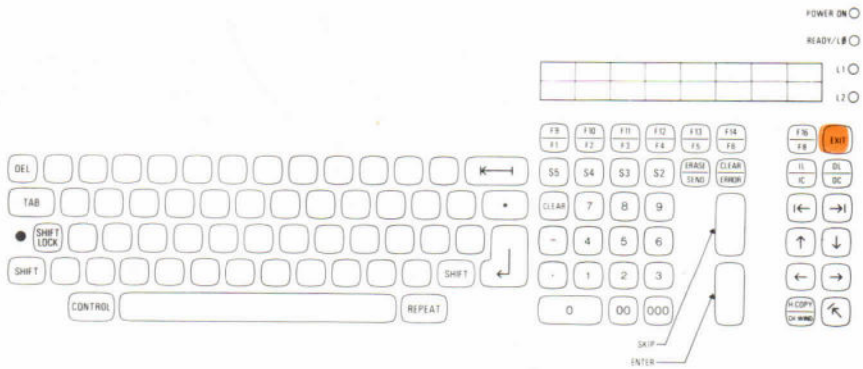

Fig. 8-9 EXIT Key in Business Keyboard

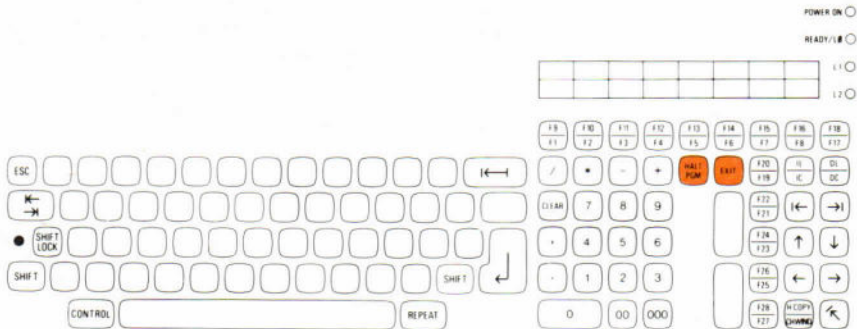

Fig. 8-10 EXIT, HALT PGM Keys in Multifunctional Keyboard

CLEAR/ERROR Key

This key is available on the business keyboard only: the first level (ERROR) is used as back space; the second level (CLEAR), used with the CONTROL key, serves to reset the error condition.

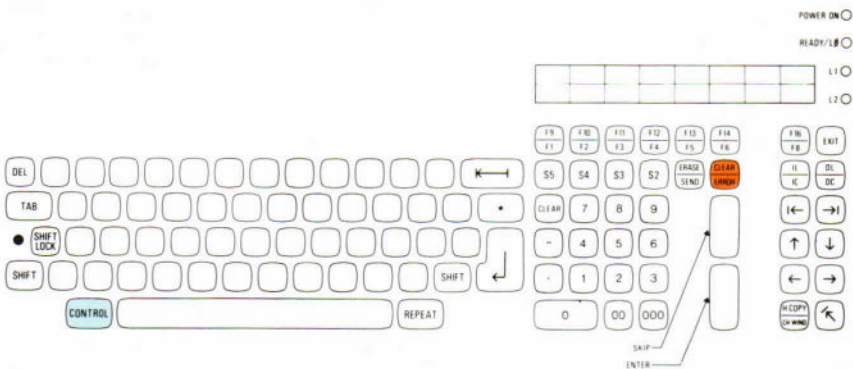

Fig. 8-11 CLEAR/ERROR Key

CL.ER Key

This key is available on the scientific keyboard only and has the same functions as the **CLEAR/ERROR** key in the business keyboard. The only difference is that the second level is obtained by using it together with the **SHIFT** key instead of the **CONTROL** key.

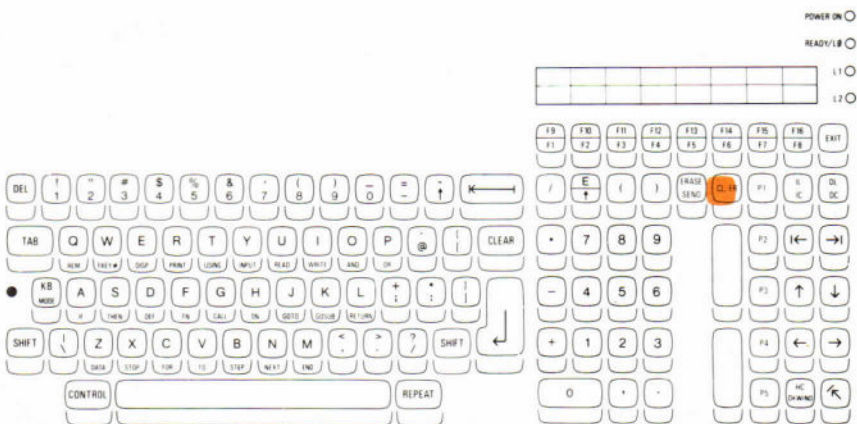

Fig. 8-12 CL.ER Key

CLEAR Key

This key cancels a line from the beginning.

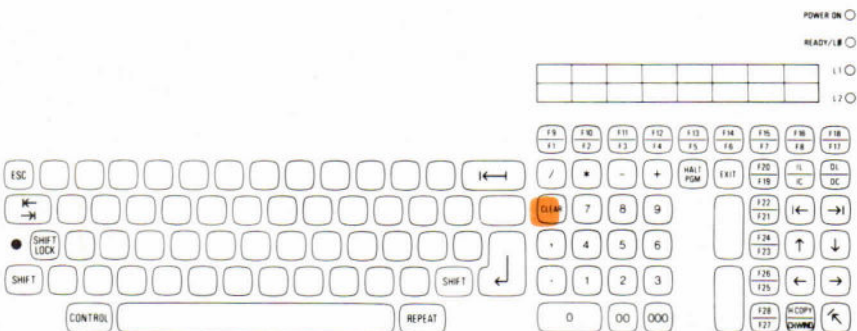

Fig. 8-13 CLEAR Key in Multifunctional Keyboard



Fig. 8-14 CLEAR Key in Scientific Keyboard

ERASE/SEND Key

This key is available on the business and scientific keyboards. The first level (SEND) is obtained in NORMAL state; the second level (ERASE) is obtained in CONTROL state (business keyboard) or in SHIFT state (scientific keyboard).

SEND is a program settable function key with a special code to which the programmer can associate a specific function. ERASE cancels the display screen, data and visual attributes, and brings the cursor back to the HOME position; it also enables scrolling and cannot be used in MCL environment.

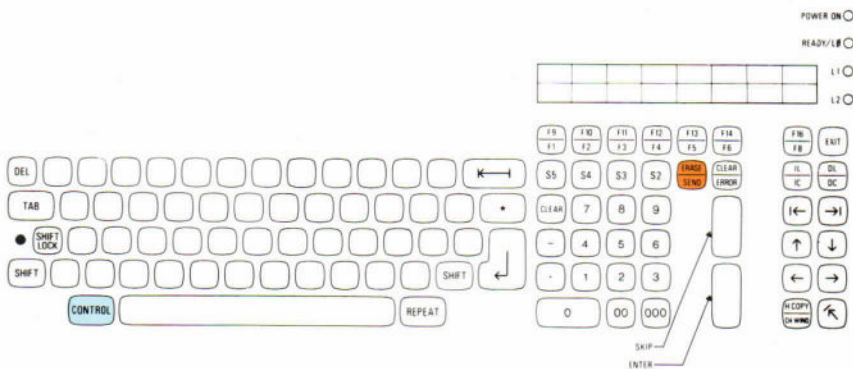

Fig. 8-15 ERASE/SEND Key in Business Keyboard

Function Keys

In all numeric + function keys keyboard sectors, there are a series of keys whose functions are assigned by program. These are:

- **Business Keyboard:** there are two types of function keys: S2 - S5 and F1 - F16. The S key series are "end-of-field entry" program settable keys; the F series are assigned to special functions.

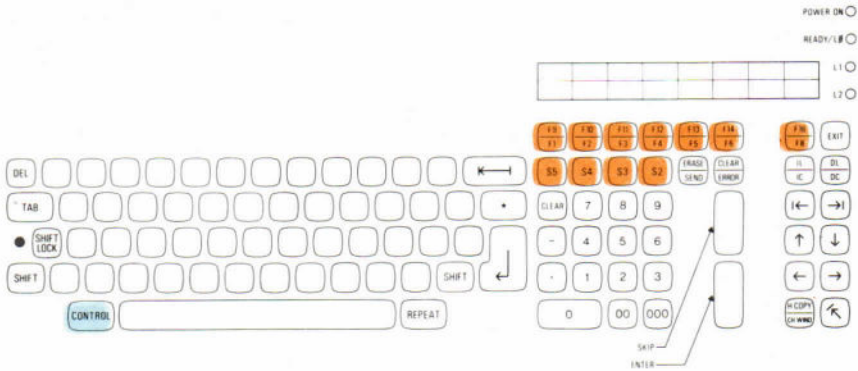

Fig. 8-16 Function Keys in Business Keyboard

- **Scientific Keyboard:** there are two types of function keys: F1 - F16 and P1 - P5. The F series are assigned to special functions; the P series are assigned to fixed functions (e.g.: graphics, zooming, virtual window scanning, etc.).

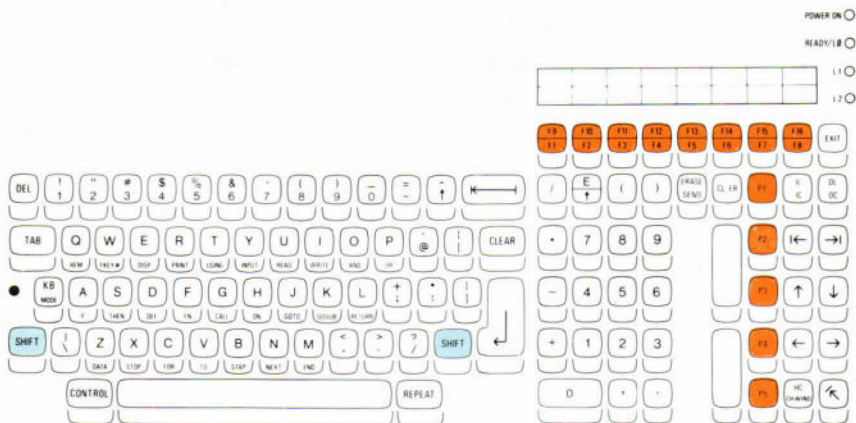
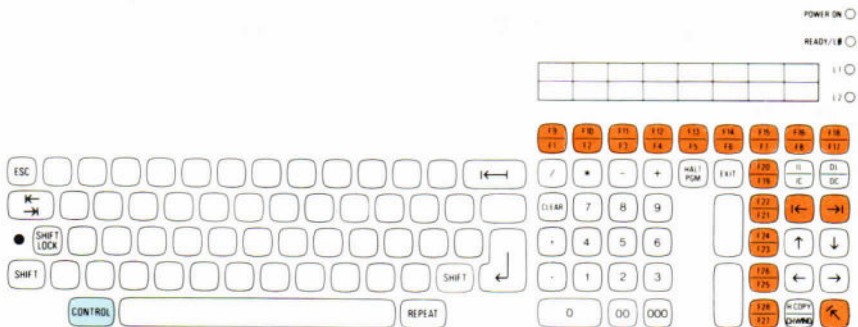
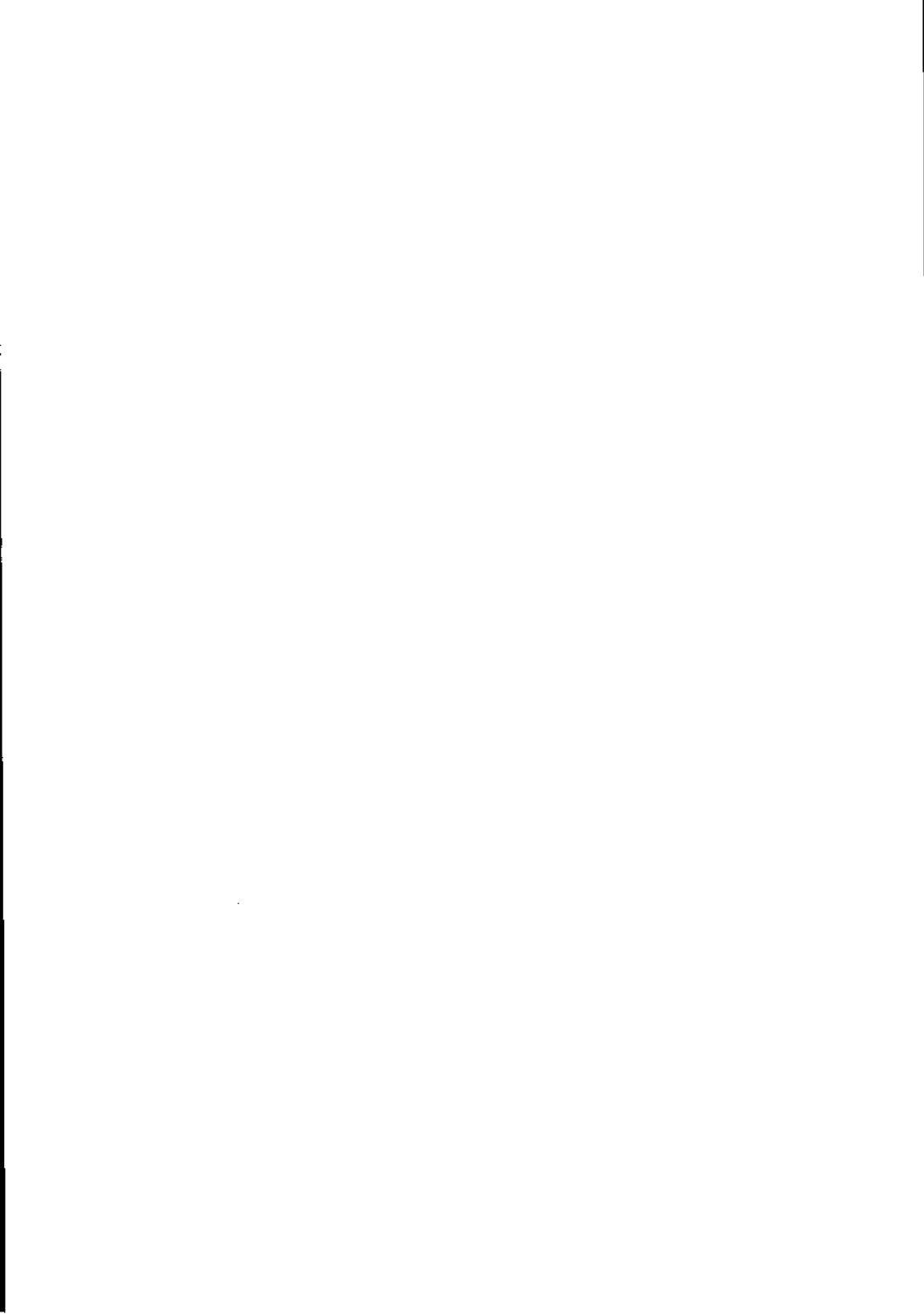

Fig. 8-17 Function Keys in Scientific Keyboard

- Multifunctional Keyboard:** the F1 - F18 keys are assigned to special functions; the other function keys are made to correspond to function keys of the business and scientific keyboards as shown in the following table:

F19 - F20	Correspond to the first level of P1 and P2 keys of the scientific keyboard
F21 - F22	Correspond to the first and second level of the S2 key of the business keyboard
F23 - F24	Correspond to the first and second level of the S3 key of the business keyboard
F25 - F26	Correspond to the first and second level of the S4 key of the business keyboard
F27 - F28	Correspond to the first and second level of the S5 key of the business keyboard
CONTROL –	Correspond to the first level of the P3 key of the scientific keyboard
CONTROL →	Correspond to the first level of the P4 key of the scientific keyboard
CONTROL	Correspond to the first level of the P5 key of the scientific keyboard





9. USING AN OLIVETTI PC AS WORK STATION EMULATOR

ABOUT THIS CHAPTER

Chapter 9 describes the way to use an Olivetti Personal Computer as an L1 MOS work station emulator (see chapter 4).

CONTENTS

L1WSE EMULATOR	9-1
ACTIVATING THE L1WSE PROGRAM	9-3
WSELAN EMULATOR	9-5
ACTIVATING WSELAN PROGRAM	9-7
OLIEMU EMULATOR	9-9
ACTIVATING OLIEMU PROGRAM	9-12
ERROR MESSAGES	9-14
CONTEXT SWITCHING ERRORS	9-14
ASYNC/ASYNC3 ERRORS	9-14
FILE TRANSFER	9-16
KEYBOARDS	9-19
KEYBOARDS 1 and 2	9-21
PB KEYBOARD WITH 105 KEYS	9-25

USING AN OLIVETTI PC AS WORK STATION EMULATOR

To be able to use the L1WSE, WSELAN, OLIEMU emulators, the PC must be provided with the MS-DOS operating system (together with the driver of the EGC board, if the latter is present) while the L1 MOS operating system must be provided with the TRANSF command for transferring of files. Other requisites are requested which differ according to the type of emulation needed. These will be indicated in the paragraph describing the single emulators.

L1WSE EMULATOR

The L1WSE emulator does not handle printers, nor work station peripherals, nor the screen windowing feature.

It is made up of a series of modules stored on diskette. These being:

- L1WSE: main emulation program with file transfer features.
- ASYNC2: serial line management driver. The serial line is configured with CONF program.
- OSKEM: alphanumeric work station management driver. It emulates almost completely the functions of the MOS OSKAR module.
- GIOM: alphanumeric/graphic work station management driver. It emulates almost completely the functions of the MOS PGU module (Rel. 5.2).
- GIOMR: alphanumeric/graphic work station management driver with reduced functions. It emulates almost completely the functions of the MOS graphic PION.
- CONF: L1WSE configuration program.
- CONTSW: program which keeps active in memory both the MS-DOS and the emulator and which permits to pass from one environment to another.

- T_KEYB: driver for handling of the PB keyboard with 105 keys.
- KEYxxx.TIB: tables containing the different national versions of PB keyboard with 105 keys. The table of the configured keyboard must be supplied as parameter of T_KEYB driver.
- PRT: driver for handling of PC parallel interface printers (known as /B type printers). It transfers nearly all the functions of the printers connected to L1, which are type /A printers, onto /B type printers. The type /B printers are not handled by the emulator (they are used for hard copy functions only) but by VISA module (see further on).
- HCBM: graphic hard copy driver for type /B monochrome printers.
- HCBC: graphic hard copy driver for type B/ colour printers.

With the L1WSE emulator it is possible to transport VISA module on PC. The VISA module handles work stations from a logical point of view according to pre-defined screen formats and allows type /B printers to be used. VISA is stored on a separate diskette which also contains the VPI module used in VISA environment for handling validation programs.

The transfer of software modules on PC for the line, the work station, the printers, transforms a Personal Computer in an intelligent work station, reducing at the same time the work of the L1 minicomputer.

The L1WSE emulator requires for emulation:

- the MOS operating system to be provided with the serial interface driver
- L1 to operate with the MOS operating system
- PC to operate with the MS-DOS operating system

To be able to use the emulator, first of all load into the PC memory all the modules required during emulation together with the VISA and VPI modules.

The modules must be loaded in the following order:

- CONF: to configure L1WSE. Whatever is configured with CONF must match what has been configured on the L1 MOS operating system. How to use the CONF program is described in the manual "System Software Configuration and Installation".
- T_KEYB: if the PC used is a Personal PB version with keyboard of 105 keys.

- OSKEM/GIOM/GIOMR
- VISA: to handle work station logically.
- VPI: if VISA needs to use validation programs.
- PRT: if VISA needs to use type /B printers.
- ASYNC2

NOTE: The work station module (OSKEM/GIOM/GIOMR) and the serial line module (ASYNC2) must be permanently stored in memory, whereas the others are temporary modules stored only when circumstances require them.

The modules are loaded into memory first of all by inserting the diskette on which they are contained into the drive, then by giving their names when the MS-DOS prompt appears on the screen followed by **CR** and also by indicating, if necessary, the drive in which the diskette is inserted. The T_KEYB module is different in that it needs the indication of the keyboard national version. The syntax of the command used for loading this module is:

T_KEYB -tKEYxxx.TIB

where xxx is the indication of the keyboard national version (see section on PB keyboard) and is made up of three to four characters.

After having loaded all these modules the emulator can be activated by running the L1WSE/CONTSW programs.

ACTIVATING THE L1WSE PROGRAM

There are two different ways to activate the L1WSE program in MS-DOS, that is:

- without context switch
- with context switch

In the first way, the program is activated directly by using the keyboard; in the second mode, it is loaded into memory through the CONTSW program and activated by using the keyboard.

The context switch is a mechanism keeping both the emulator and MS-DOS active in memory.

If you are working without the context switch, to change from MS-DOS to MOS, you should have the diskette containing L1WSE in the drive and enter when the MS-DOS prompt appears:

L1WSE

followed by **CR** . You should also indicate which drive contains the L1WSE diskette. After having loaded L1WSE you find yourself operating in MOS environment and the PC you are working with can be used exactly as a normal L1 MOS work station.

To go back to MS-DOS, you must press the following keys: **ALT F9** (keyboard 1 and 2), or **ALT WRITE** (PB keyboard with 105 keys).

Operating in this way, the change of context can be made only in emulation environment. In other words when you have returned back to MS-DOS, you must repeat the complete procedure described above. The change of context can be made only when there is no process running otherwise you would loose everything.

To operate in context switch the CONTSW diskette is to be inserted in the drive and you must enter when the MS-DOS prompt appears:

CONTSW

followed by **CR** , indicating, if required, which drive contains the CONTSW diskette.

If the following message appears:

Olivetti Context Switching Release 2.0
L1WSE loaded
press SHIFT + SHIFT to switch

it means that the CONTSW program has activated the emulator and therefore both MS-DOS and emulator are contained in memory. By pressing one of the **SHIFT** keys followed by the other **SHIFT** key, you change from one context to the other. If, perhaps, when you made the previous change of context, processes were being run, these will be continued exactly from where they were interrupted.

NOTE: The procedure described above for CONTSW program loading is valid if the interrupts connected to the emulator and to the foreground program are the default interrupts, that is, interrupt 4 for emulator and no interrupt for the foreground program. But when other interrupts are

used, it is necessary to indicate them in the CONTSW activation comand as follows:

CONTSW /cxxxx /myyyy

where xxxx and yyyy are values assumed by interrupts 5, 4, 3, 2 for emulator (xxxx) and foreground program (yyyy). The values assumed are 0, 1 (0: non-connected interrupt; 1: connected interrupt) and the same interrupt cannot be connected to both programs.

WSELAN EMULATOR

WSELAN emulator can handle two display windows and type /B printers, but no work station peripherals.

It is composed of a series of modules contained on diskette. These are:

- WSELAN: main program with file transfer functions
- OSKEM: alphanumeric work station driver, emulating almost completely the functions of the MOS OSKAR module.
- GIOM: alphanumeric/graphic work station driver, emulating almost completely the functions of the MOS PGU module.
- GIOMR: driver of alphanumeric/graphic work station with reduced functions. It emulates almost completely the functions of MOS graphic PION.
- WSECONF: WSELAN configuration program.
- CONTSW: program allowing both MS-DOS and emulator to be present in memory at the same time and with possibility of changing from one environment to another.
- T_KEYB: driver for PB keyboard with 105 keys.
- KEYxxx.TIB: tables of the various national versions available for the PB keyboard with 105 keys. The table of the configured keyboard must be given as parameter to the T_KEYB driver.
- PRINTER: driver for PC parallel interface printers (/B type). It transfers nearly all the functions of the L1 printers (/A type) to the /B type printers. /B Type printers are handled by the emulator (as work station printers) and by VISA in local mode.
- HCBM: hard copy graphic driver for /B type monochrome printers.
- HCBC: hard copy graphic driver for /B type colour printers.

The WSELAN emulator can also transport VISA module on PC used for handling the work station from a logical point of view according to pre-defined display formats. VISA is contained on a separate diskette together with VPI module used in VISA environment as validation programs interface.

The software modules transferred on PC for line, work station, and printer handling, transform a Personal Computer into an intelligent work station and, at the same time, reduces the work of the L1 minicomputer.

WSELAN uses PORTs to communicate with the MOS operating system (see chapter 4). PORTs are software modules used for handling logically the physical PC-L1 line.

Emulating with PORTs requires:

- both systems to be configured with PORTs and their relevant driver
- the presence of:
 - MOS operating system and PORTs on L1
 - MS-DOS operating system and PORTs on PC

First load the relevant driver before attempting to activate PORTs. There are three types of drivers depending on the type of physical connection made: RS232, Ethernet, Omninet.

To be able to activate the emulator, you must first load into PC memory all those modules needed during emulation together with, if necessary, VISA and VPI modules.

You must load the modules in the following order:

- WSECONF: required for WSELAN configuration. Whatever is configured with WSECONF must match what is configured for L1 MOS operating system. How to use the WSECONF program is described in the manual "System Software Configuration and Installation".
- T_KEYB: when the PC you are using is the Personal PB with 105-key type keyboard.
- OSKEM/GIOM/GIOMR
- VISA: when you handle a work station logically.
- VPI: when VISA requires validation programs.

- **PRINTER:** when using a /B type printer either as work station printer, or as printer handled by VISA. When using a work station printer you must indicate it in the CONF program.

NOTE: The work station modules (OSKEM/GIOM/GIOMR) must always be present in memory, whereas the other modules are present in memory when needed.

The modules are loaded by inserting the diskette containing them into the drive and by entering their names in response to the MS-DOS prompt, then **CR** ; sometimes it is necessary to indicate, as well, the drive in which the diskette was loaded. The only exception is the T_KEYB module, which asks you to indicate the national version of the keyboard you are using. The syntax of the command for this module is:

T_KEYB -tKEYxxx.TIB

where xxx is the indication of the keyboard national version (see the section on PB keyboards) (length: three or four characters).

You can run the programs WSELAN/CONTSW, which activate the emulator, immediately after you have finished loading the indicated modules.

ACTIVATING WSELAN PROGRAM

WSELAN can be activated from MS-DOS in two ways:

- without context switch
- with context switch

Without context switch, it is activated directly through the keyboard; but with the context switch, it is first loaded into memory by the CONTSW program, then activated using the keyboard.

Context switching is a mechanism which allows both the emulator and MS-DOS to be contained in memory at the same time.

To change from MS-DOS to MOS when operating without the context switch mechanism, you must insert the WSELAN diskette into the drive, then enter in response to MS-DOS prompt:

WSELAN

and **CR** , and indicate, if necessary, the drive containing the WSELAN diskette. With WSELAN completely loaded you find yourself operating

in MOS environment and you can use the PC as a normal L1 MOS work station.

To go back to MS-DOS you must press: **ALT F9** (keyboard 1 and 2) or **ALT WRITE** (PB keyboard with 105 keys).

Operating in this way means that context switching is possible only from emulation environment. In fact, after returning to MS-DOS, you must repeat the complete procedure as described above. Context switching should not be performed while operations are being carried out as you would loose everything.

To operate with context switch first load the diskette containing **CONTSW**, then enter in response to MS-DOS prompt:

CONTSW WSELAN

and **CR** , indicating, if necessary, the drive containing the **CONTSW** diskette.

If the following message appears:

```
Olivetti Context Switching Release 2.0  
WSELAN loaded  
press SHIFT + SHIFT to switch
```

means that **CONTSW** has activated the emulator and therefore both MS-DOS and the emulator are now contained in memory. By pressing the key: **SHIFT** and **SHIFT** again, you can switch from one context to the other. Any operations running during previous context switching will be continued exactly from where they were interrupted.

The procedure given above for **CONTSW** loading is valid if the interrupts connected to the emulator and the foreground program are the default's, that is, interrupt 4 for emulator and no interrupt for foreground program. But when not using the default interrupts, then you must indicate them clearly in the **CONTSW** activating command as follows:

CONTSW /cxxxx /myyyy WSELAN

where **xxxx** and **yyyy** are values assumed by interrupts 5, 4, 3, 2 for the emulator (**xxxx**) and foreground program (**yyyy**). The values assumed are 0, 1 (0: non-connected interrupt; 1: connected interrupt) and the same interrupt cannot be connected to both programs.

NOTE: With Ethernet/Omninet connections and **WSELAN** activated, you

will get the following message on display:

name of HOST machine:

If the OLILAN software is provided with the NAME SERVER feature, you can select the L1 system you want to be connected to from the systems configured in the network. Simply type-in the name given in NAME SERVER for the system you want and press **CR** .

OLIEMU EMULATOR

OLIEMU can handle two display windows, L1 serial interface printers (/A type) and work station peripherals, because it emulates the alphanumeric work station completely via MUX. But it cannot be used in local network connections, because it is configured for serial interface connections only.

Like L1WSE, OLIEMU is provided with a series of modules contained on diskette, that is:

- OLIEMU: main program with file transfer functions.
- ASYNC2: driver handling up to two serial lines. The second serial line is provided by the board PCT 2445 and handles a work station peripheral. Serial lines are configured with OLICONF program.
- ASYNC3: driver handling up to three serial lines. The second and third serial lines are provided by the board PCT 2445 and handle one or two work station peripherals. Serial lines are configured with OLICONF program.
- OSKEM: alphanumeric work station driver, transferring almost all the functions of MOS OSKAR module on PC.
- GIOM: alphanumeric/graphic work station driver, transferring almost all the functions of the MOS PGU module (Rel. 5.2) on PC.
- GIOMR: driver for alphanumeric/graphic work station with reduced function. The driver transfers almost all the functions of MOS graphic PION on PC.
- OLICONF: OLIEMU configuration program.
- CONTSW: program which makes it possible for both MS-DOS and emulator to be contained in memory at the same time.
- T_KEYB: driver for handling PB keyboard with 105 keys.

- KEYxxx.TIB: tables indicating the various national versions of PB keyboard with 105 keys. The table of the configured keyboard must be given as parameter to driver T_KEYB.
- PRT: driver for handling PC parallel interface printers (/B type) which transfers all the functions of L1 printers (/A type) on them. /B type printers are handled by VISA (in OLIEMU environment, the /B type printers are used only for hard copying), since the emulator handles /A type printers only.
- HCBM: graphic hard copy driver for monochrome printers with parallel interface.
- HCBC: graphic hard copy driver for colour printers with parallel interface.
- T_BPP: pin-pad and badge reader/writer driver. Requires PCT 2445 board on PC.
- T_PIM: Polling Interrupt Module used in the presence of ASYNC3 and/or T_BPP modules.

OLIEMU emulator allows the VISA module to be transported on PC for logical handling of work station according to pre-defined display formats and allows use of /B type printers. VISA is contained on a separate diskette together with the VPI module. The VPI module is used in VISA environment when validation programs are requested.

The software modules transferred on PC for handling of lines, work station, printers and peripherals, transform the Personal Computer into an intelligent work station, reducing at the same time the work load of the L1 minicomputer.

When emulating with OLIEMU it is necessary for:

- the MOS operating system to be configured with the serial interface driver
- the presence of:
 - MOS operating system on L1
 - MS-DOS operating system on PC

To be able to activate OLIEMU emulator you must first load the modules required during emulation in PC memory. The modules are loaded into memory in the following order:

- OLICONF: needed for OLIEMU configuration. Whatever is configured with OLICONF must match the L1 MOS operating system configuration. How to use OLICONF program is described in the manual "System Software Configuration and Installation".
- T_KEYB: when using a PC in Personal PB version with 105-key keyboard.
- OSKEM/GIOM/GIOMR
- T_PIM: used when ASYNC3 and/or T_BPP are loaded.
- T_BPP: for handling pin-pad and/or badge reader/writer.
- VISA: for handling work station logically.
- VPI: when VISA requires validation programs.
- PRT: when VISA requires /B type printers.
- ASYNC2: for handling two serial lines.
- ASYNC3: for handling three serial lines.

NOTE: OSKEM/GIOM/GIOMR and ASYNC2/ASYNC3 must be permanently stored in memory, whereas the others are loaded into memory when needed.

The modules are loaded into memory by mounting the diskette containing them into the drive, then by entering, in response to MS-DOS prompt, their names and **CR** . You can also indicate, if necessary, the drive containing the diskette. The only exceptions are: T_KEYB, T_PIM, T_BPP.

T_KEYB requires input of keyboard national version. The correct syntax of the command used for loading this module is:

T_KEYB -tKEYxxx.TIB

where xxx is the indication of the keyboard national version (see section on PB keyboard) (length: three to four characters).

T_PIM module requires input of the interrupt vector used; the syntax of the command used for this module is:

T_PIM -c50

The syntax of the command for activating the TBPP module is:

T_BPP -c50 -i51 -n1 -pC1_0130_02

where: -c50 indicates the T_PIM communication interrupt; -i51 indicates the interrupt that activates the driver; -n1 indicates the number of channels handled (1); -pC1_0130_02 indicates the logical name of the channel (C1), the I/O address mapping the controller (0130) and the interrupt used (02).

After you have loaded the modules indicated above, you can start running the OLIEMU/CONTSW programs which activate the emulator.

ACTIVATING OLIEMU PROGRAM

OLIEMU can be activated from MS-DOS in two ways:

- without context switch
- with context switch

Without context switch, OLIEMU is activated directly by using the keyboard; with context switch, the program is loaded into memory with the CONTSW program then activated by using the keyboard.

Context switch is a mechanism that permits both OLIEMU and MS-DOS to be contained in memory at the same time.

If you are operating without context switch, then to change from MS-DOS to MOS you must first mount the OLIEMU diskette in the drive, then enter in response to the MS-DOS prompt:

OLIEMU

and **CR** . You can also indicate, if necessary, the drive containing OLIEMU diskette. At the end of OLIEMU loading, you are in MOS environment and the PC can be used as a normal L1 MOS work station.

To go back to MS-DOS, you must press the following keys: **ALT F9** (keyboard 1 and 2) or **ALT WRITE** (PB keyboard with 105 keys).

By operating in this way, you can perform context switching from emulation environment only. In fact, when you are back to MS-DOS, you have to repeat the procedure described above. Context switching is permitted only when no operations are being run otherwise everything is lost.

To operate with context switch, mount the CONTSW diskette in the drive, then enter in response to the MS-DOS prompt:

CONTSW OLIEMU

and press **CR** . You can also indicate, if necessary, the drive containing the CONTSW diskette.

If on display you will see the following message:

```
Olivetti Context Switching Release 2.0  
OLIEMU loaded  
press SHIFT + SHIFT to switch
```

it means that CONTSW has activated the OLIEMU emulator and that you now have both MS-DOS and OLIEMU in memory. By pressing the **SHIFT** key, then the **SHIFT** key again, you can switch from one context to the other. Any operations running during the previous change of context, will be continued exactly from where it was interrupted.

NOTE: The procedure described above for CONTSW loading is correct if the interrupts connected to emulator and foreground program are the default interrupts, that is, interrupt 4 for emulator and no interrupt for the foreground program. Otherwise which interrupts are connected must be clearly indicated in the CONTSW command as follows:

CONTSW /cxxxx /myyyy OLIEMU

where xxxx and yyyy are the values assumed by interrupts 5, 4, 3, 2 for the emulator (xxxx) and foreground program (yyyy). The values assumed are 0, 1 (0: non-connected interrupt; 1: connected interrupt) and it is not possible to connect the same interrupt to both programs.

ERROR MESSAGES

The error messages likely to be generated by the emulators refer to Context Switching and line handling with ASYNC2/ASYNC3.

CONTEXT SWITCHING ERRORS

All Context Switching errors are fatal errors with impossibility of loading CONTSW. They are indicated with the following messages:

**Error: Could not load "prog-name"
Context Switch not loaded**

The message indicates emulator loading error (for example, insufficient memory).

**Error: "prog-name" is incompatible with Context Switch.
Context Switch not loaded.**

The message means that emulator binding is incorrect.

**Error: "prog-name" not found
Context Switch not loaded**

The message points out that the emulator is not contained in the current directory.

**Error: Insufficient memory
Context Switch not loaded**

The message indicates that there is not enough memory to contain CONTSW.

ASYNC2/ASYNC3 ERRORS

Every ASYNC2/ASYNC3 error is indicated by a message displayed on the last line of the display screen. The message appears as follows:

LINE ERROR XY

There can be several errors on the PC-L1 line defined at the same time. Symbol X is the hexadecimal coding of a first four-bit field; symbol Y is the hexadecimal coding of a second four-bit field. Each four-bit field identifies a possible error condition. Line errors are therefore defined by combining the errors of the first field with the ones of the second field.

Symbol X may assume the following values:

X = 0: no errors in the first field

X = 1: parity error

X = 2: framing error (unknown character format)

X = 3: parity error + framing error

X = 4: break received

X = 5: parity error + break received

X = 6: framing error + break received

X = 7: parity error + framing error + break received

X = 8: reception time out expired

X = 9: parity error + reception time out expired

X = A: framing error + reception time out expired

X = B: parity error + framing error + reception time out expired

X = C: break received + reception time out expired

X = D: parity error + break received + reception time out expired

X = E: framing error + break received + reception time out expired

X = F: parity error + framing error + break received + reception time out expired

Symbol Y may assume the following values:

Y = 0,1: no errors in the second field

Y = 2: incorrect parameters

Y = 3: line out of service

Y = 4: incorrect length

Y = 5: DSR (Data Set Ready) deactivated

Y = 6: CTS (Clear To Send) deactivated

Y = 7: non-existing channel

Y = 8,9: overrun error

Y = A: incorrect parameters + overrun error

Y = B: line out of service + overrun error

Y = C: incorrect length + overrun error

Y = D: DSR deactivated + overrun error

Y = E: CTS deactivated + overrun error

Y = F: non-existing channel + overrun error

Values 2, 4, 7, A, C, F, refer to OLIEMU only.

Examples

Message:

LINE ERROR 08

indicates an overrun error.

Message:

LINE ERROR 20

indicates a framing error.

Message:

LINE ERROR A2

indicates the following error condition: framing error + reception time out expired + incorrect parameters.

FILE TRANSFER

You can transfer files from PC to L1 MOS and vice versa as soon as you have activated the emulation program and entered in MOS environment.

The request to transfer files can come from the PC only. Files are transferred provided the L1 MOS operating system contains the TRANSF command.

Only byte-stream files can be transferred, while positional or keyed files cannot.

File transfer requests must be made when the PC is operating in MOS Shell environment. This means that if the PC you are working with is not at the moment operating in Shell, you have to close, first, the current working session then enter the Shell environment.

In Shell environment you enter **TRANSF** plus **CR** to request file transfer. Then a number of parameter acquisition messages are displayed. You respond to these messages by entering the parameters requested, after which file transfer begins.

The following table shows the parameter acquisition messages for file transferring, together with explanations and responses.

MESSAGE	EXPLANATION	RESPONSE
(T)ransmit, (R)eceive or (E)xit (T/R/E):	Enter activity desired	T/CR/: file transfer from PC to L1 R/CR/: file transfer from L1 to PC E/CR/: to terminate file transfer
INPUT filename:	Enter name of file to be transferred.	xxxxxx/CR/:file name
OUTPUT filename:	Enter name of file where the file is to be transmitted.	yyyyyy/CR/:file name
TEXT FILE(Y/N)?:	Indicate type of file to be transferred (text or binary)	Y/CR/: text file N/CR/: binary file
START TRANSF (Y/N)?:	Indicate if file transfer is to start or not.	Y/CR/: start transfer N/CR/: delete request

But responses may also be stored in a file. In this case enter:

TRANSF filename

and **CR** , where filename is the file containing the stored responses. By using this file you avoid the work of entering the required parameters each time you want to transfer a file.

The parameters you enter by typing them on the keyboard, are checked to make sure that the file names entered are correct. If there is an error in L1 or PC file, the following messages appear:

ERROR ON OPEN FILE ON MOS
ERROR ON OPEN FILE ON PC-name

If there are no errors and the entries are correct, the message displayed is:

Upload in progress...
Download in progress...

depending on whether files are transferred from PC to L1, or from L1 to PC.

When an error occurs during file transfer, the transfer operation is halted and a message is displayed:

TRANSF ABORT

or

TRANSF ABORT: print any character to continue

If file transferring is successful, the message:

TRANSF: end of copy file

is displayed. Then the first message will reappear to you on the screen to give you the possibility of transferring other files or terminating the transfer function completely.

When parameters are acquired from a file in which they are stored, no messages are displayed during transfer operations, but at the end a Completion Code is given in the STATUS variable (0: correct execution; 1: incorrect execution) and in the RET variable (CORRECT: correct execution; ABORT: incorrect execution) of the SHVAR command.

NOTE: For details on SHVAR command consult the manual:
"MCL User Guide Code 4002220 H"

KEYBOARDS

The L1WSE, WSELAN and OLIEMU emulators handle three types of keyboard:

- keyboard 1
- keyboard 2
- PB keyboard with 105 keys

in the following national versions:

- DENMARK
- NORWAY
- SWEDEN
- FINLAND
- FRANCE
- GERMANY
- HEBREW
- ITALY
- SPAIN
- SPAIN 2
- PORTUGAL
- GERMAN SWITZERLAND
- FRENCH SWITZERLAND
- UNITED KINGDOM
- USA

Which national keyboard version is used must be clearly specified in the configuration programs CONF, WSECONF and OLICONF.

The keys of the keyboards handled by the emulators are mapped in such a way to give access to all the functions available on L1 MOS keyboards.

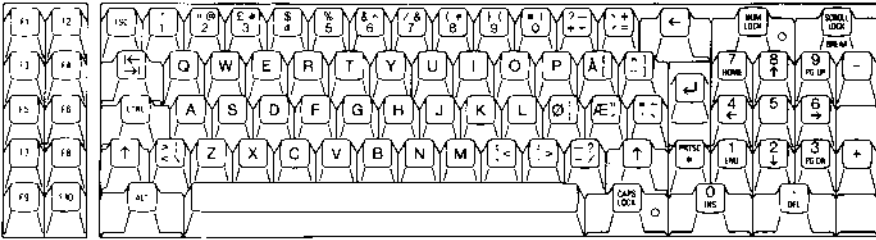

Fig. 9-1 Keyboard 1

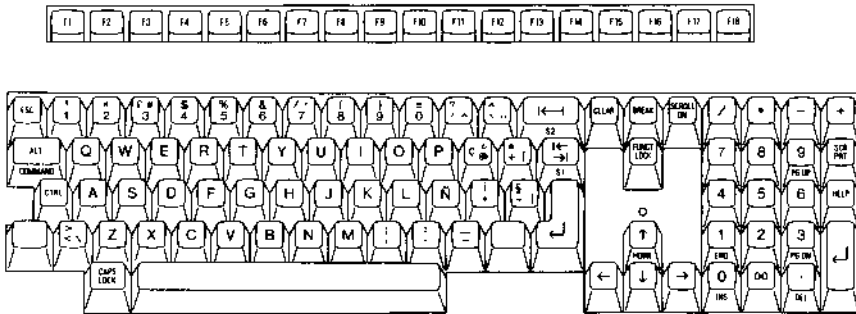

Fig. 9-2 Keyboard 2

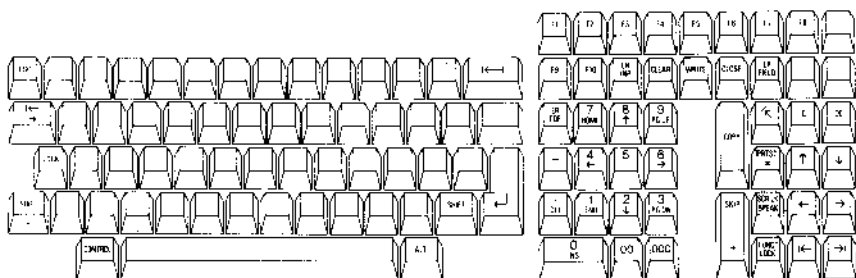

Fig. 9-3 PB Keyboard with 105 Keys

On keyboard 2, the symbols on its front are obtained by pressing the key of the symbol desired together with SHIFT or by pressing FUNCT LOCK. On keyboard 1, the numeric symbols are obtained by pressing NUM LOCK. On PB keyboard, the function symbols on the numeric pad keys are obtained by pressing FUNCT LOCK.

KEYBOARDS 1 and 2

Keyboards 1 and 2 are capable of emulating all the L1 MOS keyboards: business, scientific, multifunctional keyboards (see chapters 4 and 8). To be able to use them, you must first load the driver relevant to the national version used (the driver is normally loaded automatically in MS-DOS environment).

The table below illustrates how the functions of the three L1 MOS keyboards are emulated in keyboards 1 and 2.

L1 MOS KEYBOARD	KEYBOARDS 1 and 2
F5	F5, PGDN
F6	F6, PGUP
F11	SHIFT + F1
F12	SHIFT + F2
F13	SHIFT + F3

L1 MOS KEYBOARD

F14
F15
F16
F17
F18
F19, P1
F20, P2
F21, S2
F22, CONTROL + S2
F23, S3
F24, CONTROL + S3
F25, S4
F26, CONTROL + S4
F27, S5
F28, CONTROL + S5
CONTROL + |←, P3
CONTROL + →|, P4
CONTROL + HOME, P5
SHIFT + P1
SHIFT + P2
SHIFT + P3
SHIFT + P4
SHIFT + P5

KEYBOARDS 1 and 2

SHIFT + F4
SHIFT + F5
SHIFT + F6
ALT + END
ALT + <5>
ALT + !
ALT + 1
CONTROL + F4
ALT + F4
CONTROL + F3
ALT + F3
CONTROL + F2
ALT + F2
CONTROL + F1
ALT + F1
ALT + PGDN
ALT + PGUP
ALT + HOME
CONTROL + PGDN
CONTROL + PGUP
CONTROL + HOME
CONTROL + →
CONTROL + ←

L1 MOS KEYBOARD**KEYBOARDS 1 and 2**

HALT PGM	ALT + -
CONTROL + HALT PGM	ALT + -
EXIT	END
CONTROL + EXIT	CONTROL + END
SEND	CONTROL + F5
ERASE	ALT + F5
SHIFT + CL.ER CONTROL + <CLEAR/ERROR>	CONTROL + F6
CLEAR	ALT + F6
IC	INS
IL	SHIFT + F7
DC	DEL
DL	SHIFT + F8
←	SHIFT + F9
→	SHIFT + F10
CH. WIND	ALT + F7
HARD COPY (alphanumeric)	ALT + F10, SHIFT + PRTSC
HARD COPY (graphic/standard)	SHIFT + PRTSC
SKIP	SHIFT + ← →

NOTE:

- Keys not indicated in the table have the same meaning as in L1.
- The keys **SHIFT SHIFT** used in Context Switch environment produce a switch from emulator to MS-DOS environment and vice versa.

- The keys **ALT F7** are significant only for WSELAN and OLIEMU emulators as they produce a change of window on the display screen.
- The keys **ALT F8** used in all types of emulator, produce a hard copy of the screen content on SCRPRT file (this file is contained in the current MS-DOS directory). But remain inoperative in graphic status.
- The keys **ALT F9** used without Context Switch, produce an exit to MS-DOS from emulator environment.
- The keys **ALT F10** produce an alphanumeric hard copy on:
 - /B type printers, for L1WSE and WSELAN emulators
 - /A type printers, for OLIEMU emulator.
 but remain inoperative in graphic status.
- The MS-DOS hard copy key (**SHIFT PRN**) has the following functions:
 - if an HCBM or HCBC driver has been loaded, it performs a graphic hard copy (when operating in graphic mode) or an alphanumeric hard copy on /B type printer;
 - if none of the two drivers indicated above have been loaded, it performs the standard MS-DOS hard copy on /B type printer.
- The **BREAK** key forces a communication error condition on OLIEMU and gives the possibility of re-synchronizing MUX communications.

PB KEYBOARD WITH 105 KEYS

This keyboard emulates the L1 MOS multifunctional keyboard. To be able to use it, you must load the T_KEYB driver with the national version desired (anyone of the ones contained in the KEYxxx.TIB tables).

The names of the tables for the various national keyboard versions are:

NATION	TABLE NAME
DENMARK	KEYDA2.TIB
NORWAY	KEYNO2.TIB
SWEDEN/FINLAND	KEYFS2.TIB
FRANCE	KEYFR2.TIB
GERMANY	KEYGR2.TIB
ITALY	KEYITA2.TIB
SPAIN	KEYSP2.TIB
SPAIN 2	KEYSPA2.TIB
PORTUGAL	KEYPO2.TIB
GERMAN SWITZERLAND	KEYSVT2.TIB
FRENCH SWITZERLAND	KEYSVR2.TIB
UNITED KINGDOM	KEYUK2.TIB
UNITED STATES	KEYUSA2.TIB

As you can see from the list given, the PB keyboard with 105 keys does not dispose of the Hebrew version.

Here below is given a table illustrating how the PB keyboard with 105 keys emulates the functions of the L1 MOS multifunctional keyboard.

**MULTIFUNCTIONAL
KEYBOARD****PB KEYBOARD
WITH 105 KEYS**

F1	F1, SHIFT + F1
F2	F2, SHIFT + F2
F3	F3, SHIFT + F3
F4	F4, SHIFT + F4
F5	F5, SHIFT + F5
F6	F6, SHIFT + F6
F7	F7, SHIFT + F7
F8	F8, SHIFT + F8
F9	CONTROL + F1
F10	CONTROL + F2
F11	CONTROL + F3
F12	CONTROL + F4
F13	CONTROL + F5
F14	CONTROL + F6
F15	CONTROL + F7
F16	CONTROL + F8
F17	JUMP, SHIFT + JUMP
F18	CONTROL + JUMP
F19	ER FIELD, SHIFT + ER FIELD
F20	CONTROL + ER FIELD
F21	HOME, SHIFT + HOME
F22	CONTROL + HOME
F23	ALT + F3

**MULTIFUNCTIONAL
KEYBOARD****PB KEYBOARD
WITH 105 KEYS**

F24	ALT + F4
F25	ALT + F5
F26	ALT + F6
F27	ALT + F7
F28	ALT + F8
/	F9, SHIFT + F9, CONTROL + F9
*	F10, SHIFT + F10, CONTROL + F10
-	ER INP, SHIFT + ER INP, CONTROL + ER INP
+	CLEAR, SHIFT + CLEAR, CONTROL + CLEAR
HALT PGM	WRITE, SHIFT + WRITE
CONTROL + HALT PGM	CONTROL + WRITE
EXIT	CLOSE, SHIFT + CLOSE
CONTROL + EXIT	CONTROL + CLOSE
IC	PASTE, SHIFT + PASTE
IL	CONTROL + PASTE
DC	CUT, SHIFT + CUT
DL	CONTROL + CUT
-	IC, SHIFT + IC
CONTROL + -	CONTROL + IC
-	DC, SHIFT + DC
CONTROL + -	CONTROL + DC

**MULTIFUNCTIONAL
KEYBOARD****PB KEYBOARD
WITH 105 KEYS**

CH. WIND	←, SHIFT + ←
HARD COPY (alphanumeric)	CONTROL + ←, SHIFT + PRTSC
HARD COPY (graphic/standard)	SHIFT + PRTSC
HOME	→ , SHIFT + →
CONTROL + HOME	CONTROL + →
CONTROL + ← →	SHIFT + ← →
CLEAR	ER EOF, SHIFT + ER EOF, CONTROL + ER EOF
,	-, SHIFT + -, CONTROL + -
SKIP	COPY, SHIFT + COPY, CONTROL + COPY
ENTER	SKIP, SHIFT + SKIP

NOTE:

- Keys not indicated in the above table have the same meaning as in L1 environment.
- The keys **SHIFT SHIFT** used in Context Switch environment, produce a switch from MS-DOS to emulator environment and vice versa.
- The key |← used both in NORMAL and SHIFT conditions, is valid only for WSELAN and OLIEMU emulators as it performs a change of window on the display screen. If used in CONTROL conditions, it produces an alphanumeric hard copy on /B type printers (L1WSE and WSELAN emulators) or on /A type printers (OLIEMU emulator). This key remains inoperative in graphic status.

- The MS-DOS hard copy key (**SHIFT PRTSC**) has the following functions:
 - if the driver HCBM or HCBC has been loaded, it performs a graphic hard copy (when operating in graphic mode) or an alphanumeric hard copy on /B type printers;
 - if none of the drivers indicated above have been loaded, it performs the standard MS-DOS hard copy on /B type printer.
- The keys **ALT JUMP** produce an hard copy of the screen content on SCRPRT file which is contained in the current MS-DOS directory. These keys remain inoperative in graphic status.
- The keys **ALT WRITE** produce, when operating without Context Switch, a return to MS-DOS from emulator environment.
- The keys **ALT F1** operate as BREAK in OLIEMU environment and give the possibility of re-synchronizing MUX communications by forcing a condition error.

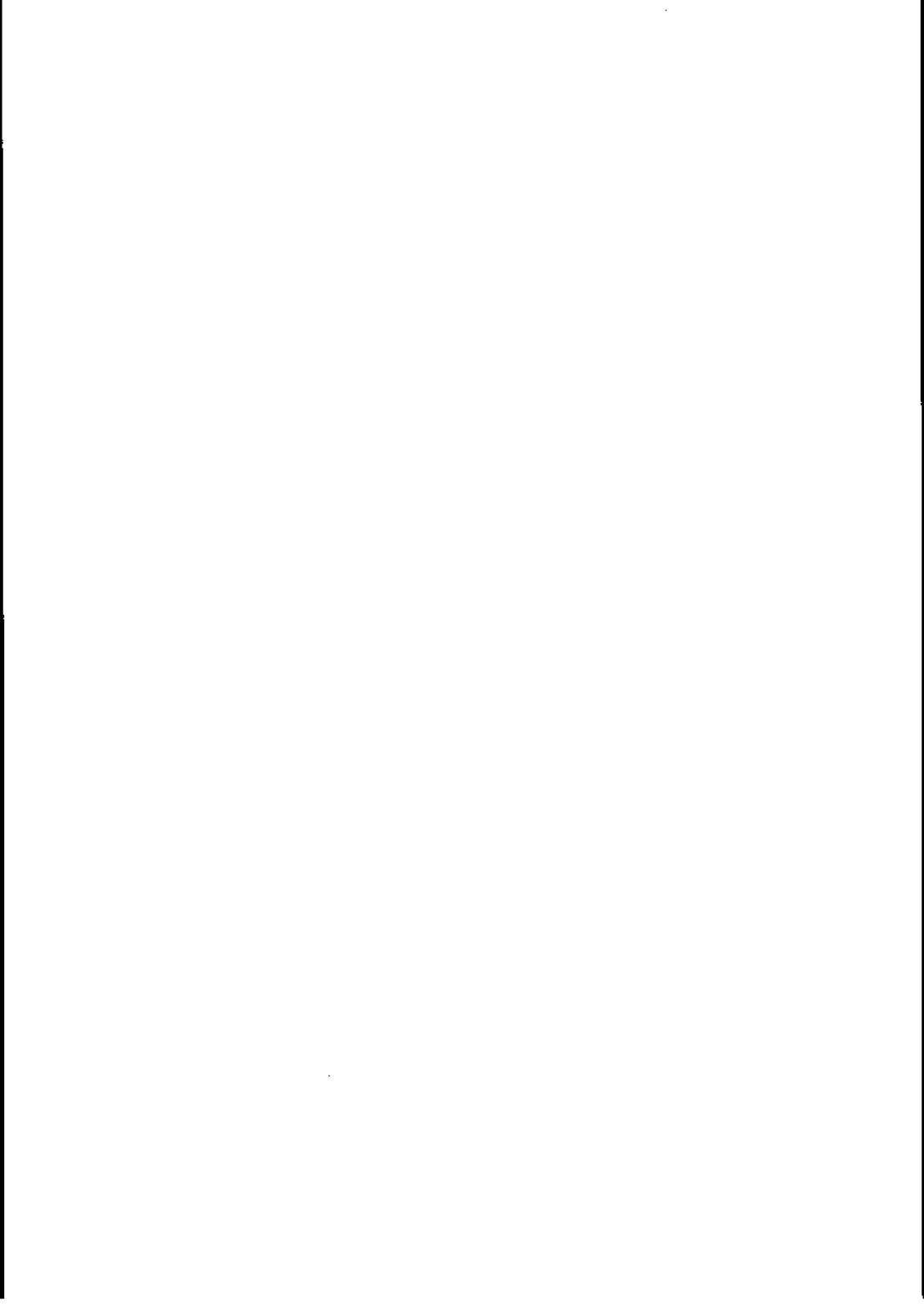

10. SHELL ENVIRONMENT

C

ABOUT THIS CHAPTER

Chapter 10 gives a general overview of the Shell environment and gives a full description of some Shell commands used. The information in this chapter is particularly valuable to work station users.

CONTENTS

THE FILE SYSTEM	10-3	PRY	10-19
SHELL COMMANDS	10-6	REMOVE	10-20
WORKING DIRECTORY COMMANDS	10-8	RENAME	10-21
SETWDIR	10-8	SHALIAS	10-21
SHWDIR	10-9	VOLUME COMMANDS	10-22
DIRECTORY COMMANDS	10-9	MKVOL	10-22
CLEARDIR	10-9	MNT	10-23
MKDIR	10-10	UNMNT	10-24
SHDIR	10-11	PRINT COMMANDS	10-24
FILE, DIRECTORY, VOLUME COMMANDS	10-12	LPQ	10-24
COPY	10-12	LPR	10-25
CPTREE	10-13	SPOOL	10-27
LIST	10-14	BATCH COMMANDS	10-28
LS	10-16	BATCH	10-28
MKALIAS	10-18	USER COMMANDS	10-29
MORE	10-18	SETPASSW	10-29
		JOB CONTROL COMMANDS	10-30

KILL	10-30
RESUME	10-31
SUSPEND	10-31
RESERVED COMMANDS	10-32
FLDUMP	10-32
FLD	10-33
VCOMPACT	10-33
VOLSR	10-33
MKENV	10-33

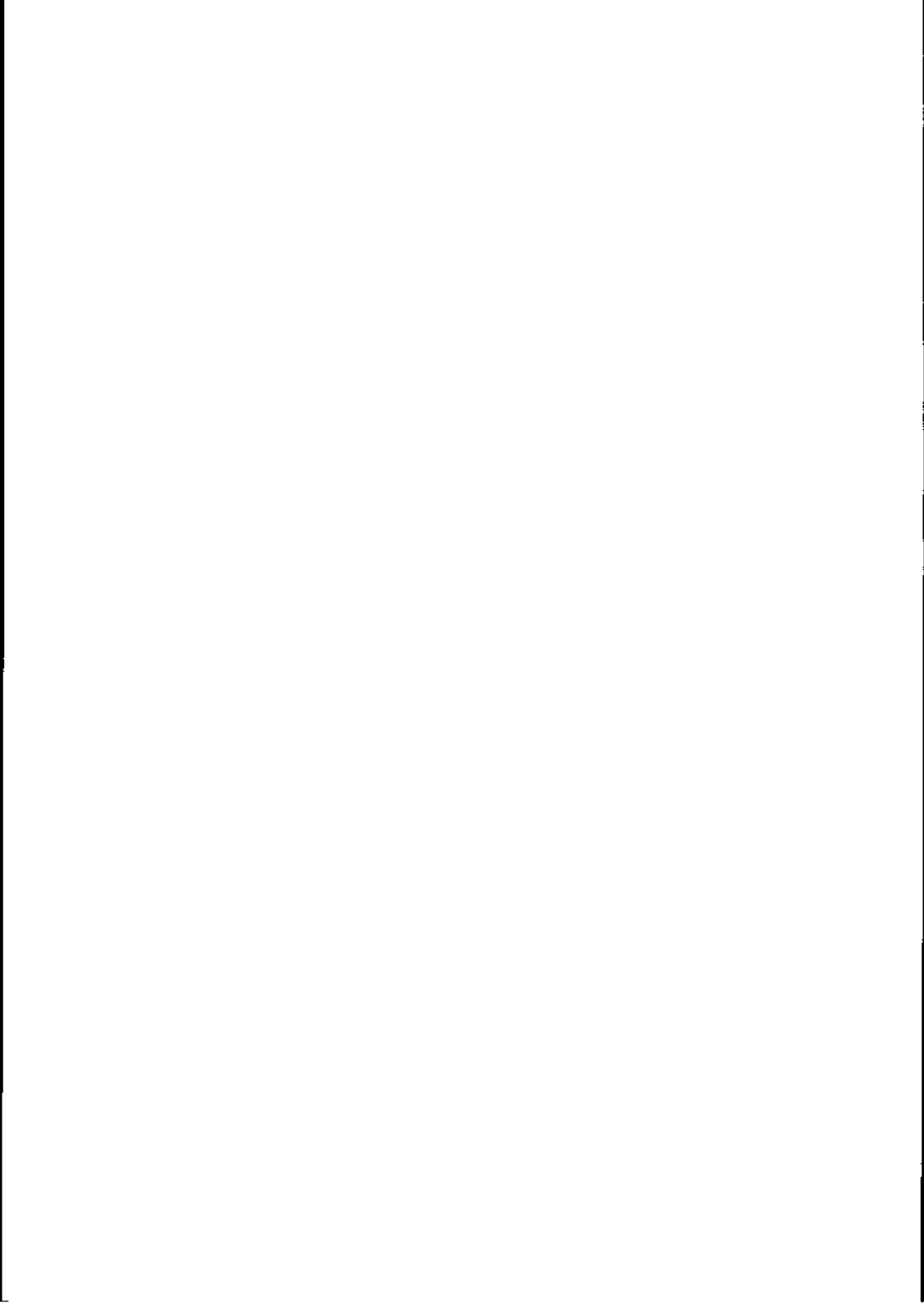

SHELL ENVIRONMENT

The Shell environment is the environment in which the system can run commands, MCL procedures and programs.

When operating in Shell the display screen is logically divided into two windows:

- the user display screen (the first n-1 lines)
- the system line (the last line on the screen).

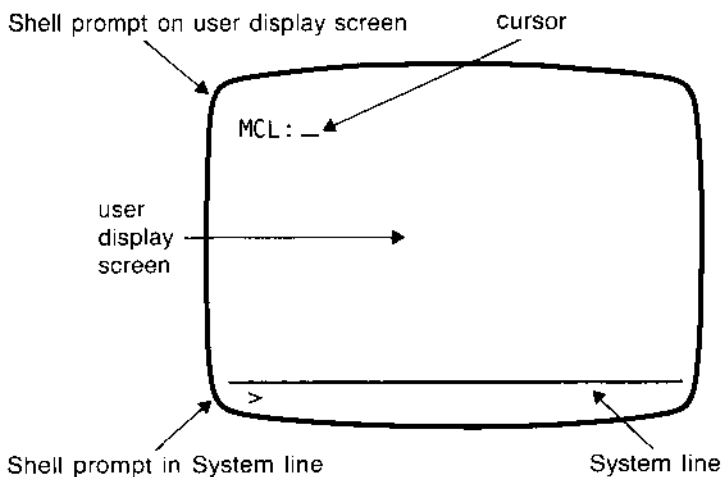

Fig. 10-1 Display Screen in Shell Environment

It is possible to move the cursor from the user display screen to the system line by pressing the **CH.WIND** key, then **CONTROL K** to activate the system line. Later, when you want to go back to the user display screen, press **CH.WIND** again and you find yourself back to the screen. The system line is used for:

- controlling asynchronously, using appropriate commands, the current user jobs (commands, MCL procedures, programs)
- displaying messages
- activating a new job and interrupting the current job. At completion of the new activated job, the interrupted job is continued.

Jobs are activated either interactively or in batch mode.

A job is activated interactively by entering in input the name of the job and the parameters required.

A job is activated in batch mode by entering in input the MCL command "BM" and the name of the job desired. The job is given a number, which is displayed on the screen, then it is queued up with other jobs in a specific job queue, and run when it becomes the first element in the queue.

The advantages of running jobs in batch mode is that a job does not need to communicate, during run time, with the work station that has activated it, leaving thus the work station free to execute other activities.

NOTE: For details on BM command, see the manual:
"MCL - MOS Command Language - Code 4002220 H".

In Shell environment you can dispose of the Spool feature.

Usually all users can access printers directly, but to make a printout they have to wait for a printer to become free.

By using the Spool feature it is possible to request a printout even when there are no printers free. The print job requested is queued up in a class and run later. The queuing up of print jobs in various classes and the assignment of printers to classes are made by the spooler program. A printer is assigned to a class by the spooler, but printers and jobs sequential access to printers are controlled by the "unspooler" processes (one for each printer).

In Shell environment it is also possible to access the system Editor for writing new files or modifying existing files (see: "Editor Reference Manual - Code 4002440 P").

THE FILE SYSTEM

In Shell environment the elements containing data to be processed appear inside the memory in a tree-type structure. This structure is called the File System.

The File System allows access to the various elements independent from the type of device on which they reside. The element from which the tree-structure starts is called the root and is indicated with the symbol `/`.

The elements of the File System are:

- **Files:** collections of data stored in logical byte sequences. Bytes are grouped logically into records. There are three types of file:
 - **Byte-Stream Files:** organized in single bytes identified by their position inside the file. The bytes are accessed by indicating the number of bytes required and the position of the first one.
 - **Positional Files:** organized in fixed-length records identified by numbers. A positional file record is accessed by indicating the number that defines it.
 - **Keyed-Files:** organized in fixed-length records identified by keys. A keyed file record is accessed by indicating the key that defines it.

All types of files can be accessed sequentially: before accessing the record (or number of bytes) required, all the records (or bytes) preceding that one are reviewed.

Files are grouped into directories.

- **Directories:** are groups of files and subdirectories.

Subdirectories are directories that descend from other directories; the directory you are working with is called the working directory.

- **Volumes:** are made up of files, directories and subvolumes. Subvolumes are volumes created within other volumes.

Each volume is identified by a directory, and every diskette or hard disk device is identified by a main volume where files, directories and subvolumes may be created.

The only volume permanently inside the memory is the root volume (`/`); all the other volumes are contained on disk and are mounted in the File System only when needed.

The IPL volume is automatically connected, in a logical sense, to the root volume at operating system load time. Without the IPL volume, the operating system cannot be loaded. The IPL volume also contains the USR directory which provides the names of all user directories. The IPL volume is usually connected logically to the system volume, which is the system manager volume.

User volumes are not connected, as a rule, to the File System but are connected only when using the appropriate Shell command. At completion of all the operations, the volume can be disconnected from the File System.

With IPL volume contained in memory, all users can have access to the system. At the beginning, the USR directory contains only the name ROOT, so the only user authorized to access the system is the system manager.

All the work station users who want to have access to the system must contact the system manager who will then create the individual user directories using a particular command.

When you, as user, have been given a directory inside the USR directory, you can access the system as described in chapter 7 and also, from your own directory, access the various File System elements.

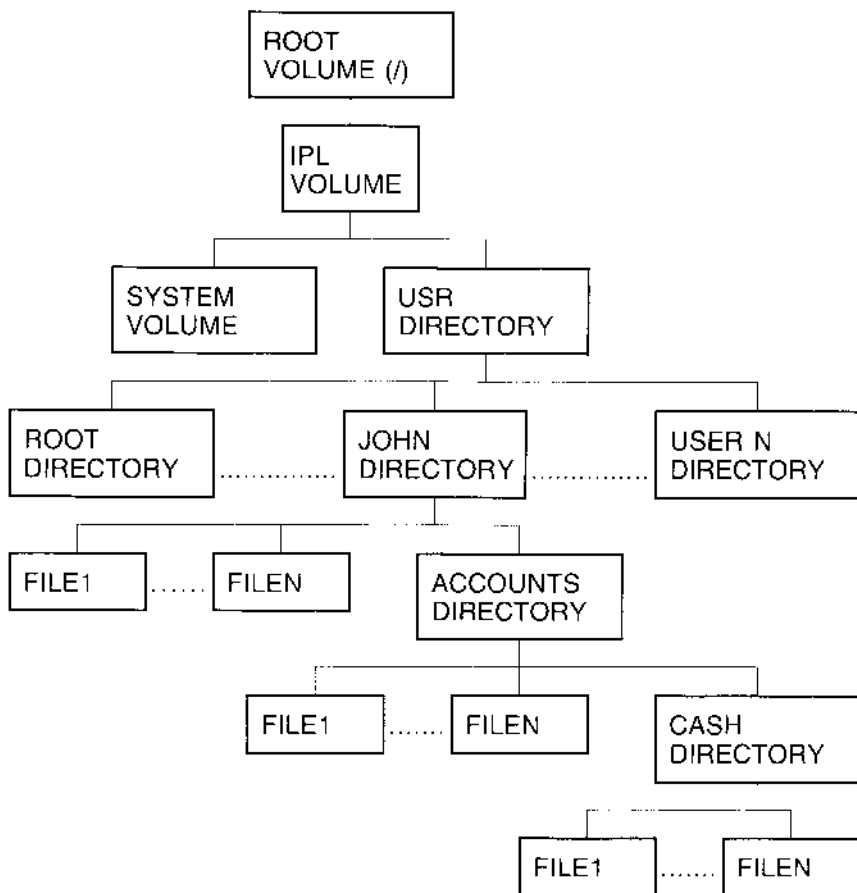

Fig. 10-2 Example of a File System

The path down the tree from the root to a given File System element is defined by a path name. A path name is made up of names separated by a slash (/) indicating the elements down the path. For example the path from root to MOS directory is defined by the path name /IPL/USR/JOHN/MOS.

When you are already on the path that from root brings you to the desired element, you need not give the entire path name and the / character preceding the name can be omitted; for example, if you are in JOHN

directory and you want to go to the BC directory, the path name you must use is MOS/BC.

SHELL COMMANDS

In this section are described some Shell commands to help you operate properly as normal work station user. The syntax of each command is illustrated in the form of a diagram.

For more details on these commands and other Shell commands as well, see the manual: "SHELL - Reference Manual - Code 4002770 Q"

Before proceeding with the description of each command, we think it useful to explain how the commands syntax diagrams are presented in this manual.

The words or symbols enclosed in circles must be entered exactly as they appear in the diagram. The words or symbols enclosed in rectangles represent the parameters you have to indicate in a command and which change each time.

For example



MORE XYZ; (MORE is a command to read a file,
XYZ is the name of the file to read)

The following convention is used to indicate a selection between the alternatives given:

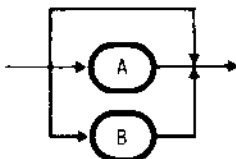

The alternatives are: 1. Run none
2. Run A
3. Run B

The example given below shows that you can indicate more than one parameter in a command:



MORE XYZ ABC; (command MORE reads files XYZ and ABC)

NOTE: The examples given refer to a file system structured as indicated in the previous paragraph. Commands can be entered as soon as the Shell prompt appears on the display screen. Commands are entered by typing on the keyboard what is indicated in the syntax diagram and terminating the entry by pressing the **CR** key.

WORKING DIRECTORY COMMANDS

SETWDIR

Replaces the current working directory by the one indicated in the command.

The syntax of this command is:

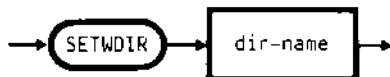

where: dir-name is the name, or path name, of the directory to replace the current working directory.

Examples:

My current working directory is //IPL/USR/JOHN:

1. To move into directory //IPL/USR/JOHN/ACCOUNTS, I type:

```
SETWDIR ACCOUNTS
```

and press **CR**

2. To move into directory //IPL/USR/JOHN/ACCOUNTS/CASH, I type:

```
SETWDIR ACCOUNTS/CASH
```

and press **CR**

3. To move into another user directory, say //IPL/USR/DAVE, I type:

```
SETWDIR //IPL/USR/DAVE
```

and press **CR** .

SHWDIR

Displays the path name of the current working directory. The command has no parameters and the syntax is as follows:

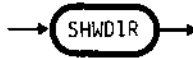

Examples:

My current working directory is /IPL/USR/JOHN, if I type:

SHWDIR

and press **CR** , I will see on the display screen the path name /IPL/USR/JOHN.

DIRECTORY COMMANDS

CLEARDIR

Deletes all the files contained in the indicated directory/directories. The syntax is:

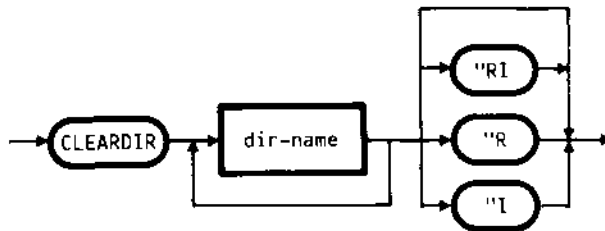

where:

- dir-name: is the name or path name of the directory
- "R: is the option to delete the directory completely

- "I": is the option for command interaction
- "RI": is the combination of "R and "I options.

Examples:

1. My current working directory is /IPL/USR/JOHN:
 - a. To delete all the files contained in the ACCOUNTS subdirectory, I type:

```
CLEARDIR ACCOUNTS
```

and press **CR**

- b. To delete all the files contained in the ACCOUNTS subdirectory and the subdirectory as well, I type:

```
CLEARDIR ACCOUNTS "R
```

and press **CR**

2. My current working directory is /IPL/USR/JOHN/ACCOUNTS/CASH. To delete all the files contained in the directory /IPL/USR/JOHN/ACCOUNTS, I type:

```
CLEARDIR /IPL/USR/JOHN/ACCOUNTS
```

and press **CR**

MKDIR

Creates directory/directories. The syntax of this command is:

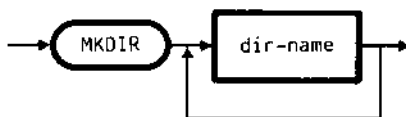

where dir-name is the name or path name of the directory.

Examples:

1. My current working directory is /IPL/USR/JOHN. To create a sub-directory called ACCOUNTS, I type:

```
MKDIR ACCOUNTS
```

and press **CR**

2. My current working directory is /IPL/USR/JOHN/ACCOUNTS. To create the directory /IPL/USR/JOHN/LETTERS, I type:

```
MKDIR /IPL/USR/JOHN/LETTERS
```

and press **CR** .

SHDIR

Displays the names of the elements within a directory and subdirectories. The syntax of this command is:



where:

- dir-name: is the name or path name of the directory
- "R: displays the names of the elements contained in the subdirectories
- "L: lists the subdirectories

Examples:

My current working directory is /IPL/USR/JOHN, and if I type:

```
SHDIR /IPL/USR/JOHN/ACCOUNTS
```

and press **CR** , I will get on display all the names of the elements contained in the IPL/USR/JOHN/ACCOUNTS directory.

FILE, DIRECTORY, VOLUME COMMANDS

COPY

Copies the content of a source file/directory/volume in a destination file/directory/volume.

But subvolume copy means copying the subvolume name only and not its content.

The syntax for this command is:

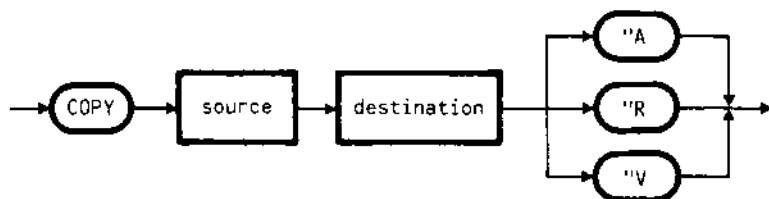

where:

- source: is the name, or path name, of the source file/directory/volume
- destination: is the name, or path name, of the destination file/directory/volume
- "A": is the option for appending byte stream files
- "R": is the option for overwriting
- "V": is the option for displaying every copied item

Examples:

My current directory is /IPL/USR/JOHN:

1. if I type:

```
COPY FILE1 ACCOUNTS
```

and press **CR**, FILE1 is copied in the ACCOUNTS subdirectory with the same name (FILE1);

2. if l type:

```
COPY FILE1 ACCOUNTS/FILE2
```

and press **CR** , FILE1 is copied in the directory /IPL/USR/JOHN/ACCOUNTS with the name FILE2.

3. if l type:

```
COPY ACCOUNTS/FILE1 ACCOUNTS/CASH
```

and press **CR** , FILE1 contained in directory /IPL/USR/JOHN/ACCOUNTS is copied in the directory /IPL/USR/JOHN/ACCOUNTS/CASH with the same name (FILE1);

CPTREE

Copies the contents of files/directories/volumes (including subvolumes) into other directories/volumes sequentially.

The syntax is:

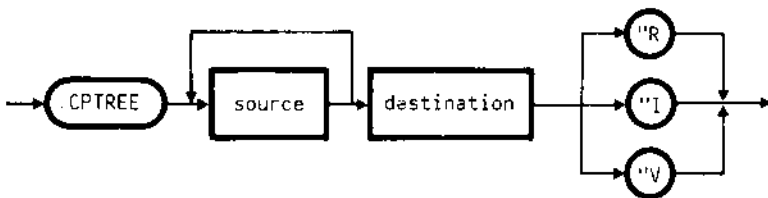

where:

- source: is the path name of the source file/directory/volume
- destination: is the path name of the destination directory/volume
- "R": is the option for overwriting
- "I": is the option for command interactive execution
- "V": is the option for displaying every copied item

Examples:

My current directory is /IPL/USR/JOHN:

1. if I type:

```
CPTREE FILE1 FILE2 ACCOUNTS
```

and press **CR**, FILE1 and FILE2 are copied in ACCOUNTS sub-directory with the same names (FILE1, FILE2);

2. if after I have created the subdirectory LETTERS I type:

```
CPTREE ACCOUNTS LETTERS
```

and press **CR**, the contents of ACCOUNTS subdirectory is copied in LETTERS subdirectory.

LIST

Displays the content of a file. The file content is displayed in sequential page screens and on the last line of each page screen it asks whether to continue with the next page screen or to exit. When only the names of files are given in a command, then only byte-stream files are displayed.

The syntax is:

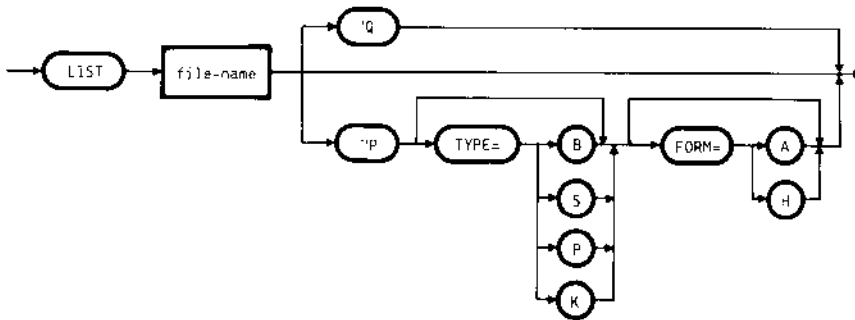

where:

- filename: is the name, or path name, of the file to display
- 'Q: is the option for requesting parameters

- "P": is the option for displaying the whole content of file
- TYPE = : is the type of file to display; the acceptable values for this parameter are:
 - B: byte-stream file
 - P: positional file
 - K: keyed file
 - S: sequential access file
- FORM = : is the type of character coding within the file; the acceptable values for this parameter are:
 - A: ASCII coding
 - H: hexadecimal coding

Example:

My working directory is IPL/USR/JOHN, if I type:

```
LIST ACCOUNTS/FILE1
```

and press **CR** , the content of FILE1 in /IPL/USR/JOHN/ACCOUNTS directory is displayed. The content of the file is displayed on several page screens and at the end of each page, I have to press **CR** to continue displaying the file.

LS

Gives information on files/directories/volumes. The syntax is:

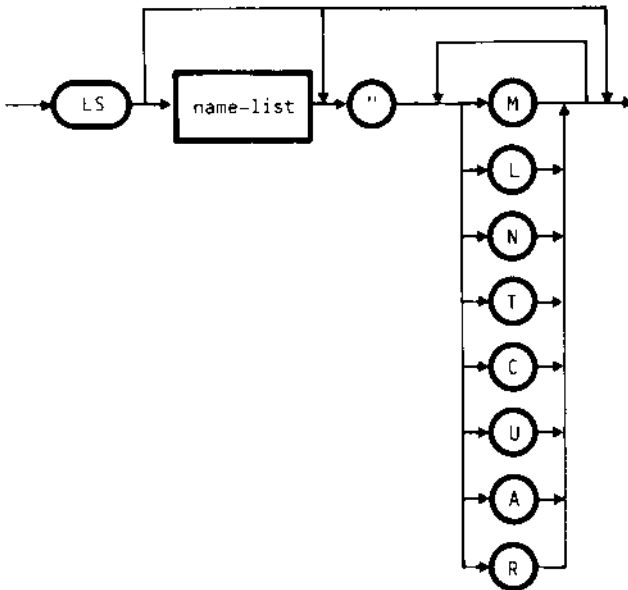

where:

- name-list: is a list of volumes/directories/files whose information is to be displayed
- "M": option to display the type of file next to the file name (alternative to option "L)
- "L": option to display the following file information:
 - name
 - type
 - file dimensions in bytes
 - user code (default value is 0)
 - creation date ("LC) or date of last updating ("LU)
 - access permission

- "N: option to display the names of the files in alphabetical order (alternative to option "T)
- "T: option to display the names of the files ordered as per last updating date (must be used with option "L and is alternative to option "N)
- "C: option, used with "L, to display the file creation date instead of last updating date
- "U: option, used with "L, to display the last file access date instead of last updating date
- "A: option to display system or auxiliary files information that are not normally displayed
- "R: option to display the content of a directory and all its subdirectories

Examples:

My working directory is /IPL/USR/JOHN, if I type:

```
LS ACCOUNTS ACCOUNTS/CASH
```

and press **CR** , I get on display information on /IPL/USR/JOHN/ACCOUNTS and /IPL/USR/JOHN/ACCOUNTS/CASH directories.

```
ACCOUNTS:
FILE1 FILE3 CASH
FILE2 FILE4
TOTAL 5 FILES
```

```
ACCOUNTS/CASH:
FILE1 FILE3
FILE2 FILE4
TOTAL 4 FILES
```

MKALIAS

Creates an alias file (a file which acts as a pointer to another file). The syntax is:

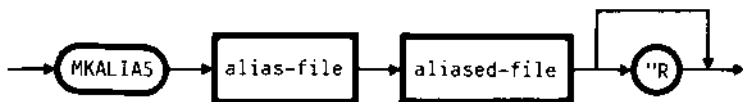

where:

- alias-file is the name of the alias file
- aliased-file is the name of the file pointed to by alias-file
- "R": option used when the aliased-file is already associated to an alias file, but the alias file must be changed with the one indicated in the command

When a Shell command indicates an alias file, the operations requested are performed on the aliased-file (file pointed to by the alias file). This does not apply to REMOVE, RENAME, and COPY commands.

MORE

Displays the contents of one or more byte-stream files in ASCII code. The syntax is:

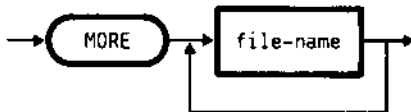

where file-name is the name or path name of the file.

Display begins with the first page of the first file in the list. At the end of every screen page you are asked to indicate what you want to do next. You can reply by entering:

- **b** : to display the next page of current file
- **CR** : to display the next line of current file
- **C** : to redisplay the current file from the beginning
- **N** : to display the beginning of the next file on the list
- **P** : to display the beginning of the previous file on the list
- **Q** : to terminate the command and return to Shell environment
- **S** : to search for a character string (maximum 40 characters) which will be requested later with ENTER STRINGS:. After the string is located, press **CR** to continue the search string command.
- **W** : to display the name of the current file

PRY

Displays information on files/directories/volumes. The syntax is:

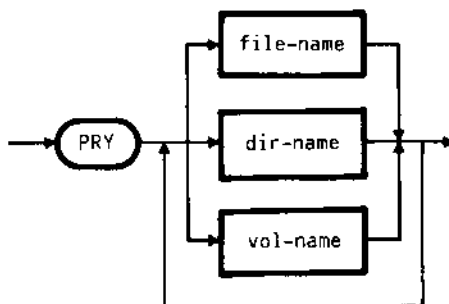

The information displayed is: type of element, creation date, last access date, last updating date, physical dimensions, allocation unit.

REMOVE

Deletes all the names/path names of files/empty directories/volumes indicated in a list.

The syntax is:

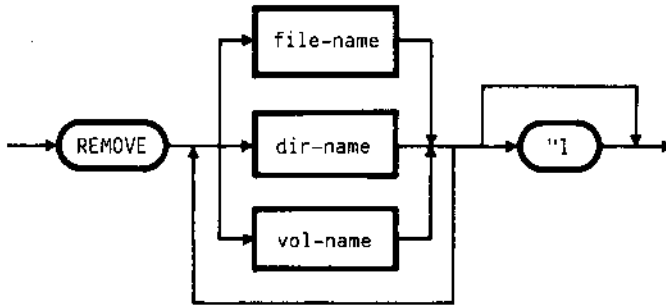

where:

- file-name: is the name/path name of a file
- dir-name: is the name/path name of an empty directory
- vol-name: is the name/path name of a volume
- "|": is the indication of command interactive execution.

Example:

My current directory is /IPL/USR/JOHN, if I type:

```
REMOVE FILE1 FILE2
```

and press **CR** , FILE1 and FILE2 are deleted

RENAME

Changes name of a file/directory/volume indicated in the parameter "source" with the name given in parameter "destination".

The syntax is:

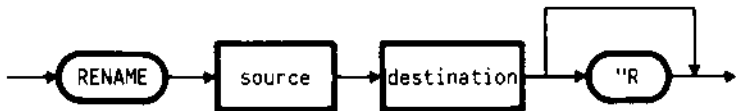

where:

- source: is the name/path name of the file/directory/volume to be renamed
- destination: is the name/path name to be assigned to the file/directory/volume
- "R": is the overwrite option

Example:

My current directory is /IPL/USR/JOHN, if I type:

```
RENAME FILE1 01
```

and press **CR** , FILE1 changes its name into 01.

SHALIAS

Displays the content of one or more alias files. The syntax is:

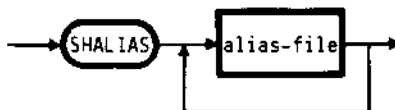

On display appears the complete path name of the file associated to the alias file. For example, if I want to display the path name of the files pointed

to by the alias files AL1 and AL2, I must enter "SHALIAS AL1 AL2" and press **CR** , provided I have used before the commands: "MKALIAS AL1 /IPL/USR/JOHN/ACCOUNTS/FILE1" and "MKALIAS AL2 /IPL/USR/JOHN/ACCOUNTS/FILE2", then on display there will appear:

AL1:
/IPL/USR/JOHN/ACCOUNTS/FILE1

AL2:
/IPL/USR/JOHN/ACCOUNTS/FILE2

VOLUME COMMANDS

MKVOL

Creates a volume. The syntax is:



This is an interactive command and asks you to enter the following parameters:

- name of volume to create (length = 14 characters max.)
- name of device (hard disk or diskette) where the volume is to be created if you want to create a main volume; or, if you want to create a sub-volume, the path name of the directory in which the subvolume is to be created. If creating a main volume and the diskette device is used, the command must be preceded by the reserved command MKENV.

The names that indicate the device used are: MF n , for 5.25 inch diskette units; FL n , for 8 inch diskette units; HD n , for hard disk units (n is the unit number).

- size of volume in bytes
- maximum number of files that can be created in the volume
- volume identifiers: user code, release number and level.

The input of each parameter must be followed by <CR>. After creating the volume you can connect it logically to the file system by using the command MNT.

MNT

Logically connects volumes contained on hard disk or diskette to the file system. With this command the system is able to recognize the volume and to access its data. The command syntax is:

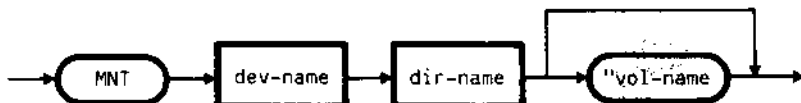

where:

- dev-name: is the name of the device containing the volume
- dir-name: is the name/path name of the directory (or logical volume) defining the volume. The directory cannot be assigned with the same name given to the physical volume.
- "vol-name: is the name of the physical volume to connect to the file system and created previously with the command MKVOL. With this option, the system controls the name of the volume contained on the device defined in dev-name with the name defined in vol-name. If the names are different then the system displays an error message.

Example:

My current directory is /IPL/USR/JOHN, and if I type:

```
MNT FL1 ACCOUNTS/DEP "VOLDEP
```

and press **CR**, the volume named VOLDEP, contained on device FL1, is connected logically to directory /IPL/USR/JOHN/ACCCOUNTS/DEP.

UNMNT

Deletes the logical connection of system/physical volume made with command MNT and removes the logical volume from the file system. The command syntax is:

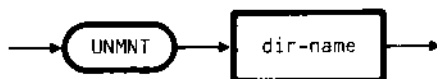

where dir-name is the name of the directory defining the volume

Example:

My current directory is /IPL/USR/JOHN, if I type:

```
UNMNT ACCOUNTS/DEP
```

and press **CR**, the volume defined by directory /IPL/USR/JOHN/ACCOUNTS/DEP (see MNT) is disconnected logically from the system and the directory is deleted.

PRINT COMMANDS

LPQ

Displays status of the spooler classes. If no parameters are given, the command displays status of the spooler classes associated to the system printer; if parameter n is given, then the command displays status of the n spooler class.

The command syntax is:

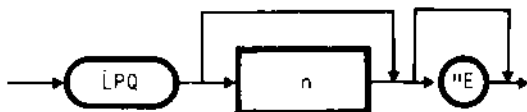

where option "E causes display of the dimensions and title (40 characters max.) of the print jobs.

Example:

I am in anyone of my working directories and I am using the Spooling System; if I enter:

LPQ 2

and press **CR** , on display appears the status of spooler class 2. A number is assigned to every print job and jobs can be in any of the following status:

HOLD: job is waiting to be printed

READY: job is ready to be printed when it becomes the first of its class

RUN: Job is being printed

LPR

Prints the content of one or more byte-stream files. A print job can be sent directly to one of the system printers, or it can be queued to one of the spooler classes. If a job is sent directly, it is printed only if the printer is not assigned to a spooler class and there are no other printings running on that printer at the moment.

The command syntax is:

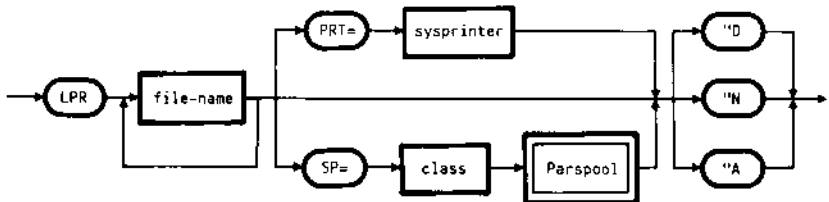

where:

- file-name: is the name/path name of the byte stream file to print
- PRT = sysprinter: indicates the system printer which the print job is assigned to; sysprinter can be given the value from 1 to 8, which correspond to SYSPRTn printers (n = 1-8).
- SP = class: indicates the spooler class where the print job is enqueued; class accepts any value from 1 to 8.

- "D": is the option to delete the file after printing (it must be used with the "N option)
- "N": is the no-copy option
- "A": is the option for aligning the paper in the printer

The syntax of PARSPPOOL is as follows:

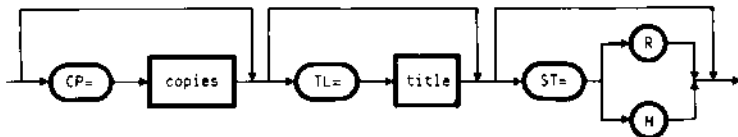

where

- CP = copies: is an integer indicating the number of copies for the print job (the default number is 1).
- TL = title: indicates the title of the print job which must not be longer than 40 characters.
- ST = : indicates the status in which the print job is enqueued to the spooler class; R (Ready status) or H (Hold status).

Example:

My current directory is //IPL/USR/JOHN, if I type:

```
LPR ACCOUNTS/FILE1 ACCOUNTS/FILE2 SP = 2
```

and press **CR** , the print job of FILE1 and FILE2 contained in ACCOUNTS subdirectory, is enqueued in spooler class 2.

SPOOL

It is an interactive command used by the system manager and, limitatively, by all users too. It communicates with the spooler program. The syntax is:

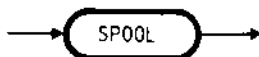

When you use this command, a menu appears on the display listing the functions available. You select a function by entering one of the following:

- L: to display class status
- J: to display print job status
- H: to set a print job in HOLD status
- R: to set a print job in READY status
- K: to remove a print job from a class
- P: to interrupt current job printing
- S: to display spooler environment
- E: to return to Shell environment

BATCH COMMANDS

BATCH

It is an interactive command used by the system manager and, limitatively, by all users too. It communicates with the batch environment. The command syntax is:



When activated you get a menu on the display listing the available functions. You select a function by entering one of the following:

- L: to display the batch class queue
- J: to display the status of a job enqueued in the batch class
- H: to set a job in HOLD status (waiting to be executed)
- R: to set a job in READY status (ready to be executed)
- K: to remove a job from the batch class
- E: to return to Shell environment.

USER COMMANDS

SETPASSW

Permits users to define their own passwords. It is an interactive command and can be activated from any directory. The command syntax is:



If there is no password and you enter:

SETPASSW

and press **CR** , on display there appears:

ENTER NEW PASSWORD:

you must reply by typing-in the name of the password (maximum 8 characters long) and press **CR** .

If you enter a password longer than 8 characters, you get the following message:

RETYPE:

and you must retype-in the password correctly, then **CR** .

You will then be asked to repeat the password:

REPEAT:

Enter the password once again, then **CR** . If the two passwords entered are not the same, the following message appears:

BAD PASSWORD

Then the Shell prompt reappears and you have to start from the beginning again.

On the other hand, if the password is already there, when you type SETPASSW and press **CR** , you get the following message:

ENTER OLD PASSWORD:

Now type-in the name of your password and press **CR** . If you enter a name longer than 8 characters, you are asked to re-enter password name:

RETYPE:

From now on the procedure continues exactly like as if there weren't any old password. When the message:

REPEAT:

appears and, of course, as you do not repeat the entry of a new password, then the old password entered remains valid and the system accepts it.

JOB CONTROL COMMANDS

KILL

Destroys the job (program, command or procedure) which the user has activated. This command is entered in the system line.

The syntax of this command is:



The command has no parameters.

Example:

The PROG program is running; if I activate the system line (the **CH.WIND** + **CONTROL K** keys) then type:

KILL

and press **CR**, the program aborts and I automatically get back my prompt on the display screen.

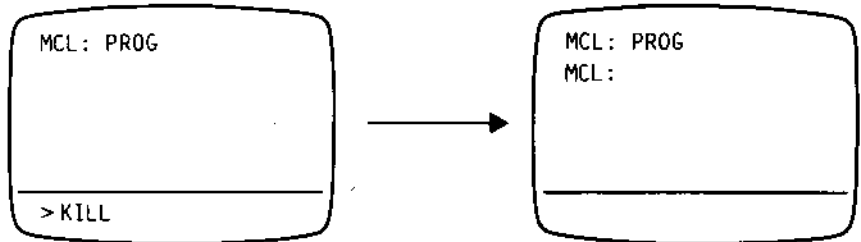

RESUME

Resumes running of a program or procedure previously interrupted by the command **SUSPEND**. The syntax of this command is:



SUSPEND

Interrupts the running of a job to allow other jobs to be activated. The interrupted job is continued by using the command **RESUME**. The command is to be entered in the system line as follows:



Example:

I am running the PROG program, but if I activate the system line then type:

SUSPEND

and press **CR** , the program is interrupted and automatically I go back to my prompt on the display screen. At this point I can start running another job, for example program PROG1. Then at completion of PROG1, I can continue running the interrupted program PROG, by typing:

RESUME

and press **CR** .

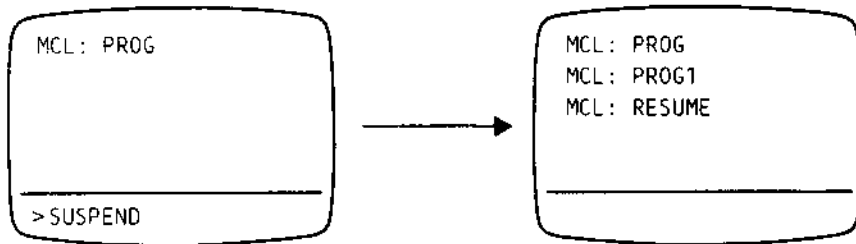

RESERVED COMMANDS

This section describes the commands reserved to the system manager and which are interesting for work station users to know.

FLDUMP

This is a command for:

- saving a hard disk volume in one or more diskettes
- checking the content of the HEADER LABELS of the volume segments saved on diskettes
- restoring onto hard disk the content of a volume previously saved on diskette(s)
- copying the content of a diskette onto another diskette

- copying the content of diskette(s) onto hard disk
- restoring onto diskette(s) the section of the hard disk previously copied from diskette

FLDUMP is activated either interactively or non-interactively.

FLD

Command for:

- saving onto diskette(s) any files/directories/volumes contained on hard disk
- restoring onto hard disk any file/directory/volume previously saved on diskette(s)
- initializing a diskette
- displaying information on diskette contents

FLD is activated either interactively or non-interactively.

VCOMPACT

Optimizes the use of space in one or more indicated volumes.

VOLSR

Transfers a disk volume onto streaming tape cartridge (STC) and vice versa.

MKENV

Initializes track 0 of a diskette. This command must always precede MKVOL which is the command to create the main volume on a non-used diskette.



A. SELF-DIAGNOSTIC MESSAGES

ABOUT THIS APPENDIX

Appendix A lists the error messages generated by the system during self-diagnostic operations. These messages can help an operator to remove the errors found, where possible, or are useful information for the Field Engineering technician that has to make the necessary intervention.

CONTENTS

ERROR DETECTION AND SIGNALLING	A-1
STEADY LIGHT CODES	A-2
FLASHING LIGHT CODES	A-3
MESSAGES ON DISPLAY SCREEN	A-4

A. SELF-DIAGNOSTICS MESSAGES

Self-diagnostics is a phase in which the system is tested to check the correct operating conditions of all the modules required in the IPL operations following next.

ERROR DETECTION AND SIGNALLING

The modules tested during self-diagnostics are:

- CPU
- System RAM memory
- IPL devices and controllers.

The diagnostic messages may refer to hardware faults (these need the intervention of a Field Engineering technician), or to errors made by the operator (therefore easily corrected by the operator himself), or signals only.

There are two types of messages:

- a) messages consisting of one digit appearing in steady light
- b) messages consisting of three digits appearing in flashing light

STEADY LIGHT CODES

They appear on the one-digit display of the basic console as one-character codes. But they appear on the six-digit display of the extended console as one character preceded by two spaces, a period, and other two spaces (e.g.: xx.xx.C where x = space, C = code value).

CODE	ERROR DESCRIPTION
1	CPU Error
2	System RAM error
3	Invalid vector acquired at interrupt time
4	ROM debugger activation
5	Waiting for result of first IPL attempt
6	Activating "segment trap" after bootstrapper
7	Activating "non-maskable interrupt" after bootstrapper
9	No instruction is implemented after bootstrapper
A	Privileged instruction implemented after bootstrapper
B	System call after bootstrapper
C	Non-vectored interrupt after bootstrapper
D	System waits for IPL switching to make a "Memory Dump". If switching is not performed or the software module that handles the operation is not available, IPL is continued normally.
E	Waiting for result of extended diagnostics, if requested

Tab. A-1 Table of Error Codes in Steady Light

With M70 systems, a two-digit code "bE" may also appear to indicate a bus error.

FLASHING LIGHT CODES

These codes are related to the dialogue with IPL controllers and are made up of four characters. On the basic console display the four characters appear one after the other, whereas on the extended console they appear all together on the last righthand four digits of the display.

The table below illustrates the meaning of this type of codes.

CODE	ERROR DESCRIPTION
.	This character is the synchronization symbol for interpreting the error code indicated by the following three characters.
x	Error code with different meanings: "x" = 1 Controller error "x" = 2 Peripheral unit error "x" = 4 Device reading error "x" = 8 Device not mounted correctly, or device not containing the operating system
y	Indicates the slot of the rack where the controller containing the error is mounted
z	Indicates the unit containing the error

Tab. A-2 Table of Error Codes in Flashing Light

MESSAGES ON DISPLAY SCREEN

If the system manager uses an alphanumeric, graphic work station, the diagnostic codes appear both on console display and on work station screen. The steady light codes appear as follows:

C **REL. C.0**

— ROM-LOADER release

— Error code (has the same meaning as the error codes displayed on the diagnostic console)

The flashing light codes appear as follows:

x y z **REL. C.0**

— ROM-LOADER release

— Error code (has the same meaning as the error codes displayed on the diagnostic console)

B. SYSTEM MESSAGES

ERROR MESSAGES

These are messages generated by the operating system when it finds errors that halt the normal running of its activities.

The table below illustrates the various error codes, their significance, the monitor that generates them or the type of error.

The codes are displayed on the system console and on the debugger terminal display screen, if present.

CODE	SIGNIFICANCE	NOTE
7	I/O error during environment activation. Re-prepare device.	IPL error
8	There is no MOS environment. Re-prepare device.	IPL error
21	I/O error during bootstrapping. Re-prepare device.	IPL error
22	File /SYS\$/IPL not found during bootstrapping. Re-prepare device.	IPL error
23	Memory erasing error during "unattended" bootstrapping.	IPL error

CODE	SIGNIFICANCE	NOTE
31	I/O error during IPL operations. Re-prepare device.	IPL error
32	System does not find the IPL device.	IPL error
33	Kernel primitive run time error during IPL.	IPL error
34	Initialization module error. Make sure that the configuration file is similar to hardware configuration.	IPL error
35	Insufficient memory during IPL.	IPL error
36	File \$CON not found during IPL.	IPL error
37	There is not enough memory to contain the \$CON file.	IPL error
51	Kernel data areas are inconsistent.	Error code generated by Kernel
52	There is a vectored interrupt with incorrect Z8001 PSA identifier.	Error code generated by Kernel
53	Power failure: non-masked interrupt.	Error code generated by Kernel

CODE	SIGNIFICANCE	NOTE
54	Parity error: non-masked interrupt.	Error code generated by Kernel
55	Lock time out expired in a multiprocessor system.	Error code generated by Kernel
56	Incorrect dip-switches configuration for the CPU board associated to IPL.	Error code generated by Kernel
57	Incorrect dip-switches configuration for the set of CPU boards.	Error code generated by Kernel
58	No-masked interrupt or "Segment Fault" in system or "shared" status.	Error code generated by Kernel
59	Loss of vectored interrupt.	Error code generated by Kernel
61	Control Process error: stack requested during system or "shared" status.	Error code generated by PMM
62	Control Process error: attempt to extend PMM segment.	Error code generated by PMM

CODE	SIGNIFICANCE	NOTE
63	Segments table is inconsistent during MMU table resetting at Memory Process initialization time.	Error code generated by PMM
64	Bit-map updating error during search for a contiguous memory area matching the number of pages requested.	Error code generated by PMM
65	Memory Process fatal error during segments table initialization.	Error code generated by PMM
66	Segments table is inconsistent during Memory Process initialization.	Error code generated by PMM
67	The IPL device name is incorrect.	Error code generated by PMM
68	Fatal error: segments table is inconsistent during PMM segments movements.	Error code generated by PMM
69	Incorrect message sent to Control Process.	Error code generated by PMM
71	The \$IPL module is not consistent with the machine on which it is mounted.	Mounting error
72	The \$PMM module is not consistent with the machine on which it is mounted.	Mounting error

CODE	SIGNIFICANCE	NOTE
99	Default error	

IPL WARNINGS

During IPL process, the system loads the Operating System from the magnetic unit indicated in Main Memory and controls that the configuration file matches the actual hardware configuration used.

If they do not match, the system generates messages indicating the errors found and sends them on the display of the MASTER terminal.

The errors found by the system during this phase do not affect IPL operations, which are continued normally, but are simple warnings of the present situation for operator.

MESSAGE	DESCRIPTION
(WARNING): FD DEVICE NOT FOUND or NO FD/MFD DEVICE	The FD/MFD device defined in configuration file is not mounted.
(WARNING): HD DEVICE NOT FOUND or NO HD DEVICE	The Hard Disk defined in configuration file is not mounted.
(WARNING): SCT DEVICE NOT FOUND or NO SCT/MT DEVICE	The SCT/MT device defined in configuration file is mounted.
(WARNING): KEY TABLE NOT FOUND	The keyboard used is not the one indicated in configuration file.

MESSAGE	DESCRIPTION
(WARNING): CHECK NUMBER ALPHANUMERIC WS or ALPHANUM WS NUM	The number of alphanum WS connected differs from no. defined in configuration file.
(WARNING): CHECK NUMBER GRAPHIC WS or GRAPHIC WS NUM	The number of graphic WS connected differs from no. defined in configuration file.
(WARNING): CHECK NUMBER KANJI WS or KANJI WS NUMBER	The number of KANJI WS connected differs from no. defined in configuration file.
(WARNING): CHECK NUMBER PIN PAD DRI or PIN PAD DRV NUM	The number of pin pad drivers used differs from no. number defined in configuration file.
(WARNING): CHECK NUMBER CADP DRIVER or CADP DRV NUM	The number of cash adapter drivers used differs from no. defined in configuration file.
(WARNING): CHECK NUMBER PRINTER DRI or PRINTER DRV NUM	Number of printer drivers is greater than number of printers configured.
(WARNING): CHECK NUMBER BADGE DRIVE or BADGE DRV NUM	Number of badge reader drivers is greater than number of badge readers configured.

MESSAGE	DESCRIPTION
(WARNING): CHECK NUMBER MICR DRIVER or MICR DRV NUMBER	Number of MICR drivers is greater than number of MICR units configured.
(WARNING): DATA LINK WARNING or DATA LINK	The line controller defined in configuration file is not present.
(WARNING): CHECK NUMBER HDU CONTROL or HDU CTRL NUMBER	Number of HDU controllers is different from number defined in configuration file.
(WARNING): CHECK NUMBER RS DRIVER or RS DRV NUMBER	The number of lines available on RS232/CL driver is different from number requested.



This equipment conforms to EEC Directive 82/499 regarding the prevention and elimination of radio frequency disturbances.

Warning: This equipment generates, uses, and can radiate radio frequency energy and if not installed and used in accordance with the instructions manual, may cause interference to radio communications. It has been tested and found to comply with the limits for a Class A computing device pursuant to Subpart J of Part 15 of FCC Rules, which are designed to provide reasonable protection against such interference when operated in a commercial environment.

Operation of this equipment in a residential area is likely to cause interference, in which case the user, at his own expense, will be required to take whatever measures may be required to correct the interference.

NOTICE

Ing. C. Olivetti & C. S.p.A. reserves the right to make any change in the product described in this manual at any time and without notice.

Code 4036160 T (0)
Printed in Italy

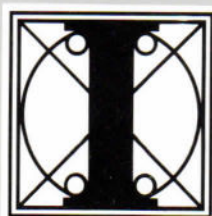

olivetti